

# FORM 1 END OF TERM 2 EXAMS 2021

*For making schemes call Mr Machuki  
0795491185/0778626409.*

*Comprises all the subjects.*

**END OF TERM 2 EXAMS  
BIOLOGY  
FORM 1**

**NAME:** .....**CLASS:** .....**ADM:** .....

1. State the name given to the study of  
(2mks)

(i) Insects

.....

(ii) Classification of living organisms.

.....

2. (a) Name the products of complete hydrolysis of sucrose.  
(1mk)

.....

.....

(b) What happens to these products named in (a) above, when they are excess in the  
the body of man. (2mks)

.....

.....

3. (a) State the roles of light in plant nutrition.  
(2mks)

.....

.....

(b) Give a reason why glucose formed at the end of photosynthesis is converted  
at once into starch.  
(1mk)

.....

.....

4. (a) State the formula for calculating linear magnification of a specimen when  
using a hand lens.  
(1mk)

.....

.....

(b) Give **one** functional advantage of use of the following microscopes.  
(2mks)

(i) Light Microscope

.....

(ii) Electron Microscope.

.....

5. An investigation was set up as shown in the diagram below.

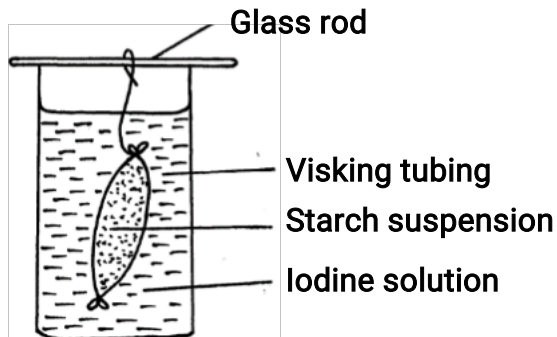

After 30 minutes, starch suspension had turned blue-black while iodine solution retained its colour.

(a) Name the physiological process that was being investigated in the experiment.  
(1mk)

.....

(b) Account for the results observed after 30 minutes.  
(3mks)

.....

.....

.....

.....

6. Define the term osmosis. (2mks)

.....

.....

.....

7. (a) Distinguish between homodonts and heterodonts. (1mk)

.....

.....

(b) A certain mammal has no incisors, no canines, 6 premolars and 6 molars in the upper jaw.

In the lower jaw, there are 6 incisors, 2 canines, 6 premolars and 6 molars.

(i) Write down the dental formula of this mammal.

(1mk)

.....

.....

(ii) What is the mode of nutrition of this mammal? ( 1mk)

.....

8. The reaction represented by equation below occurs in the body

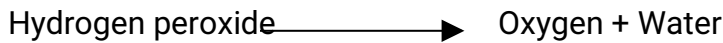

(a) Name enzyme Z (1mk)

.....

(b) Name an organ in the human body where this reaction occurs (1mk)

.....

(c) State the biological importance of the reaction above (1mk)

.....

9. State how each of the cells below are specialized to carry out their functions

(a) Palisade cell (1mk)

.....

(b) A sperm cell (1mk)

.....

10. State the functions of each of the following organelles.

(i) Ribosomes (1mk)

.....

(ii) Golgi apparatus (1mk)

.....

11. Name the bond that exists between amino acids during condensation process of forming proteins?

(1mk)

.....

.....

12. Explain how the following factors affect the rate of photosynthesis

(a) Concentration of carbon (iv) oxide.

(1mk)

.....  
.....

(b) Light intensity

(1mk)

.....  
.....

13. Study the figure below which shows a type of epithelial tissue

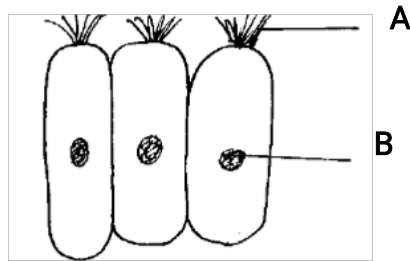

(a) State the name of structure A.

(1mk)

.....  
.....

(b) Give an example in humans where this epithelium is found

(1mk)

.....

14. The diagram below represents part of the human digestive system.

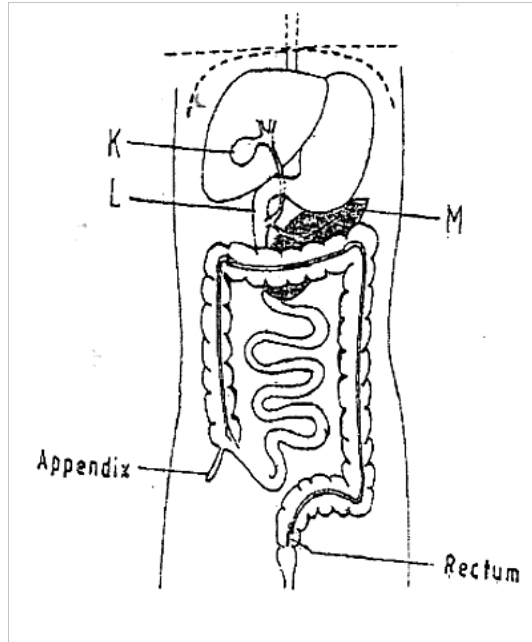

Name the organs labeled L and M.

(2mks)

L: .....

M: .....

15. Some form one students wanted to collect the following animals for study in the Laboratory. State the suitable apparatus they should use.

i) Flying insects ..... (1mark)

ii) Crawling stinging insects ..... (1mark)

iii) Small animals from tree barks ..... (1mark)

16. Study the diagram below and answer the questions that follows

a) Identify the structures labeled A and B (2marks)

b)  
What

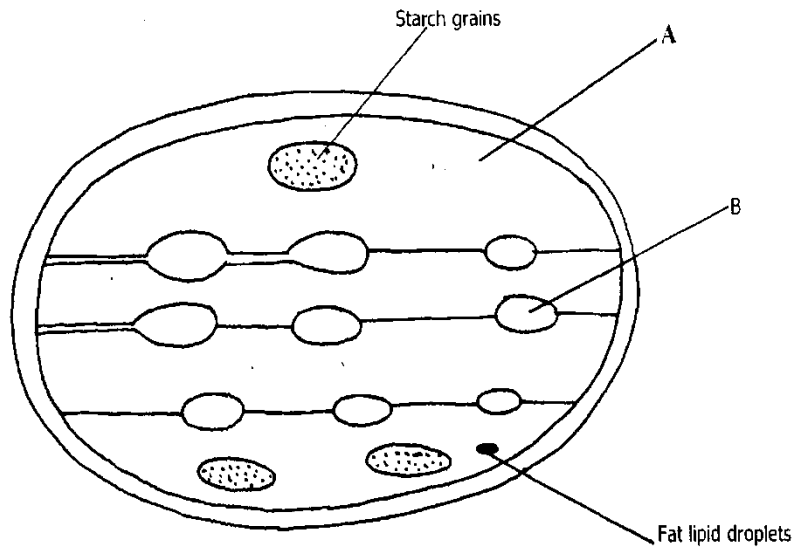

b)

process takes place in the parts labeled A and B (2mark)

17. A student estimated the diameter of a field of view to be 2.8mm. The diameter was occupied by four onion cells. Estimate in micrometers the diameter of onion cell. Show your working. (2 marks)

18. The diagram below represents structure found in the walls of ileum.

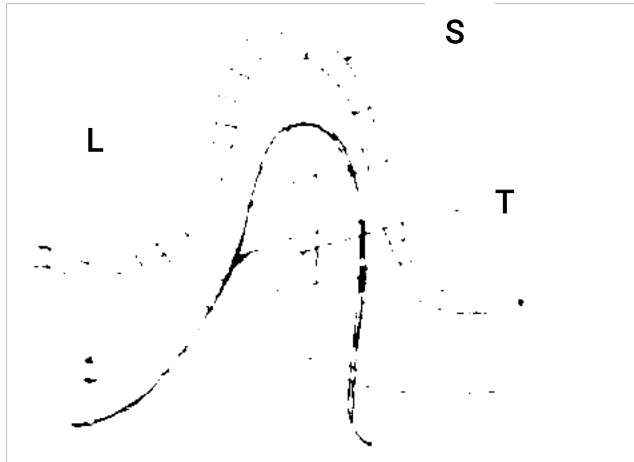

a) Identify the structure shown in the diagram. (1 mark)

b) Name parts labeled S, T and L. (3 marks)

S .....

T .....

L .....

c) Name products of digestion which are absorbed into; (2 marks)

L .....

T .....

d) State how the above structure is adapted to its function. (2 marks)

.....  
.....  
.....



19. The diagram below represents a set up that was used to investigate a certain process in a plant.

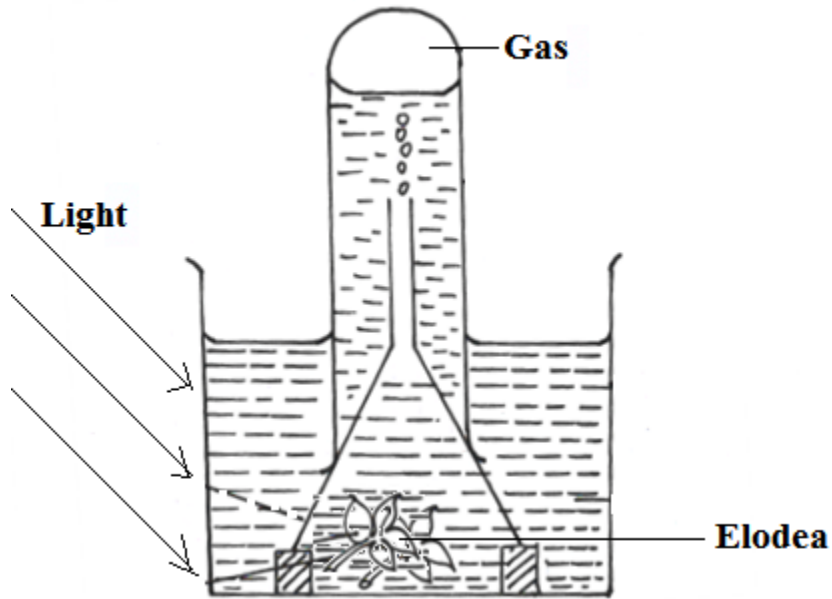

(a) State the process that was being investigated. (1 mark)

.....  
.....

(b) Other than the factors shown, state two factors that would affect the process named in (a) above. (2 mark)

.....  
.....

20. Outline two roles of active transport in human beings. (2 marks)

.....  
.....

.....  
21. Write the role of the following parts of microscope.  
(3marks)

i) Mirror

.....  
.....

..... ii) Diaphragm

.....  
.....

.....  
ii) Coarse adjustment knob

.....  
.....  
.....

22. Explain why plant cells do not burst when immersed in distilled water.(2mks)

.....  
.....  
.....  
.....  
.....

23. (a) State two functions of bile juice in the digestion of food? (2marks)

.....  
.....  
.....  
.....

(b) How does substances concentration affect the rate  
of enzyme reaction? (1mark)

.....  
.....  
.....  
.....

24. The diagram below represents a cell

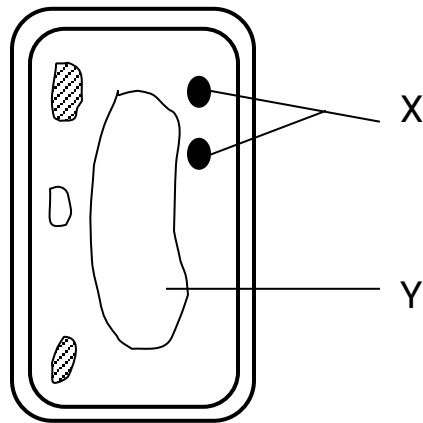

a) Name the parts labeled X and Y (2marks)

X .....

Y .....

b) State why the structures labeled X would be more on one side than the other side.(1mark)

.....

.....

.....

.....

25. a) What is diffusion (2marks)

.....  
.....  
.....  
.....

b) How does diffusion gradient affect the rate of diffusion? (1mark)

.....  
.....  
.....

NAME.....ADM.NO:.....SIGN.....

CHEMISTRY

FORM ONE

TERM II YEAR 2021

TIME: 2 HOURS

**INSTRUCTIONS TO STUDENTS**

1. Answer all questions in this question paper.
2. All your answers must be written in the spaces provided in this question paper.

**FOR EXAMINERS USE ONLY**

Question	Maximum score	Candidates score
1-16	70	

1. (i).Define Chemistry. (1mk)
- (ii)State three roles of chemistry in the society. (3mks)
2. (i)What is a drug. (1mk)
- (ii)(a). Name three frequently abused drugs. (3mks)
- (b).State two long term effects of drug abuse. (2mks)
3. (a). State three apparatus used for measuring accurate volumes of liquids. (3mks)

(b). Give two reasons why most laboratory apparatus are made of glass.  
(2mks)

4. What is a flame? (1mk)

5. Putting off flames is one of the laboratory safety rules. State three other rules.  
(3mks)

6. (i) What is a mixture? (1mk)

(ii). State two physical means of separating a mixture.  
(2mks)

7. Otieno, a form one student at Anestar High School accidentally mixed sulphur and iron filings.

(a). Suggest an appropriate method of separation you would advise him to use to separate the mixture.  
(1mk)

(b). Give a reason for the choice of your answer. (2mk)

(c). Describe how he would use the method named in (a) above to separate the sulphur and iron filings.

(3mks)

8. (a) Name two substances that sublime when heated.

(2mks)

(b). Give two reasons why dry ice (solid carbon (IV) oxide) is preferred to be used in cold boxes by ice cream vendors over ordinary ice.

(2mks)

9. The set up below shows the apparatus used to demonstrate simple distillation process.

Study it and answer the questions that follow.

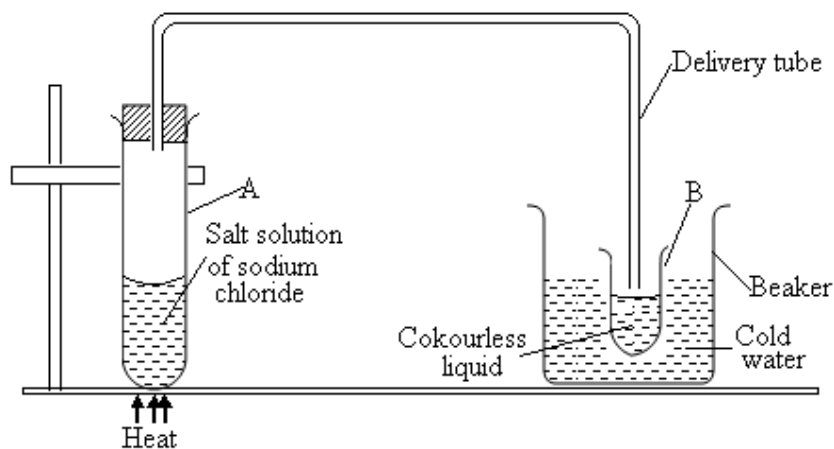

(a) What is observed in the delivery tube as the solution boils?

(1 mk)

(b) What is the purpose of cold water in the beaker?

(1 mk)

(c) What is observed in the test tube A after all the solvent has evaporated?

(1 mk)

(d) Name the liquid you expect to collect in tube B.

(1 mk)

10. Differentiate between physical and chemical changes as follows:

(4 mks)

Chemical change	Physical change
(i)	
(ii)	
(iii)	
(iv)	

11. Write the chemical symbols of the following elements.

(5 mks)

(i) Copper –

(ii) Sodium –

(iii) Potassium –

(iv) Lead–

(v) Calcium –

12. Spots of pure pigments A and B and a mixture Z were placed on a filter paper and allowed

to dry. The paper was then dipped in a solvent. The results obtained were as on the paper chromatogram.



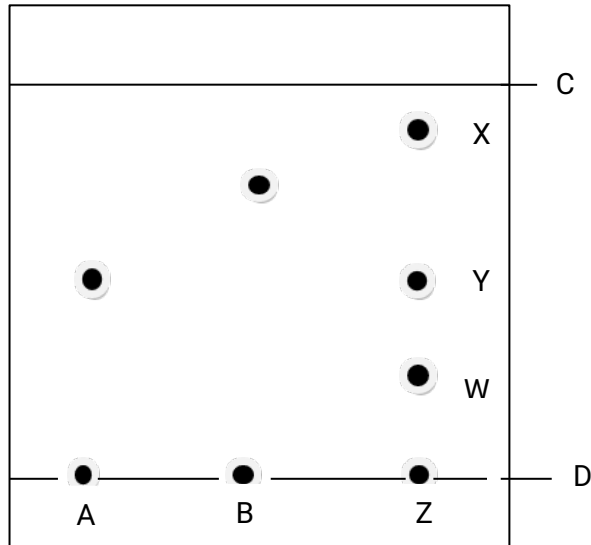

(a) Which line is the:  
 (i) base line – (2mks)

(ii) Solvent front –

(b) Which of the pure pigments was a component of Z? Explain.  
 (2 mks)

(c) (i) Name a solvent that is used in paper chromatography.  
 (1 mk)

(ii) Why is water not a suitable solvent in paper chromatography?  
 (1 mk)

(d) Write a word equation for the reactions between:  
 (i) Carbon and oxygen - (2 mks)

12. (a). Define the following terms:

I. A saturated solution. (1mk)

II. Crystallization.  
(1mk)

(b). Give two industrial applications of crystallization as a method of separating soluble substances from their solutions.  
(2mks)

13 define the following terms. (3mks)

a. Atoms:.

b. Molecules.

c. Compound.

14. Name the elements present in the following compounds (3mks)

a. Sodium bromide:

b. Lead sulphate:

c. Potassium iodide:

15. State three observation made when a piece of sodium is placed on the surface of water.(3mks)

16. Give three application of chromatography. (3mks)

17. Give one advantage of commercial indicators over flower extract indicators.  
(1mk)

**END TERM TWO EXAM, 2021**

**CRE FORM ONE**

**NAME: .....ADM**

1. Explain how the teaching of CRE promotes National Unity? (6mks)

2. Explain why the Bible is referred to as a library of books. (8mks)

3. Identify the promises God gave to Abraham. (7mks)

4. Describe the covenant between God and Abraham (Genesis 1:1-19) (8mks)

5. Explain the differences between the Jewish and African practices of circumcision. (10mks)

6. How did God manifest Himself during the making of the Sinai Covenant? (5mks)

7. Explain how God prepared Moses to become a future leader for his people. (6mks)

8. Explain the reasons for Kingship in Israel. (8mks)

9. Outline the duties of Judges in Israel. (5mks)

10. State King David's achievements in Israel. (8mks)

11. Name types of gods in the Canaanite religion. (6mks)

12. Give the characteristics of local Cannanites religion. (8mks)

13. Outline six actions of jeroboam that promoted the spread of idolatry in northern kingdom(6mks)

14. Give the responsibilities of elders in A.T.S. (6mks)

15. Give ways through which Christians can fight corruption in the society(5mks)

NAME..... ADM NO.....CLASS.....

**AGRICULTURE FORM 1**

**END TERM 2 2021**

**TIME: 1 ½ HOURS**

**Attempt all questions**

1. Give four importance of land preparation in crop production (4mks)

.....  
.....  
.....

2. List four factors that determines the type of irrigation used in crop production (4mks)

.....  
.....  
.....

3. Give five characteristics of fertile soil (5mks)

.....  
.....  
.....

4. Mention five importance of drainage as a land reclamation method (5mks)

.....  
.....  
.....

5. List four types of livestock farming practices (4mks)

.....  
.....  
.....

6. List the three types of a spanner and give two maintenance practices. (5mks)

.....



7.a. Define the term minimum tillage. (1mks)

.....  
.....

7.b. Give five minimum tillage practices. (5mks)

.....  
.....

8. List four factors that influence soil formation (4mks)

.....  
.....  
.....

9. Give four importance of treating water (4mks)

.....  
.....  
.....

10. What are some of the agricultural practices that pollute water? (3mks)

.....  
.....  
.....

11. Differentiate between a garden trowel and a masons trowel (2mks)

.....  
.....  
.....

12.State two effects of HIV/AIDS on agriculture (2mks)

.....  
.....  
.....

13. Give the uses and maintenance each of the following equipment

a)Wheel barrow (2mks)

.....

.....  
b)Spoke shave  
(2mks)  
.....  
.....

c)Milking churn

(2mks)

.....  
14.State the reasons for proper care and maintenance of farm tools and equipments  
(4mks)  
.....  
.....  
.....

15.Give the 3 fields of horticultural farming and describe what they entail  
(3mks)  
.....  
.....  
.....

16. The diagram below shows some workshop tools. Study them and answer the questions that follow

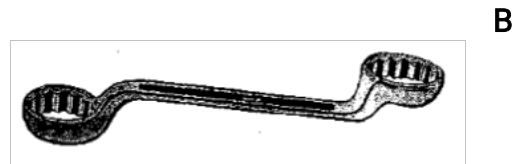
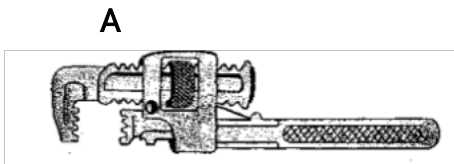

(a) Identify the tools A and B  
(2mks)

A.....

B.....

(b) State the correct use of the tool labeled A  
(2mks)

.....  
(c) Explain **one** maintenance practice carried out on the tool A  
(1mk)

.....  
17. State **four** categories of farm tools and equipment  
(4mks)  
.....

.....  
.....  
.....

Name:.....Class:.....Adm No:.....

**END TERM EXAM - 2021  
FORM 1  
BUSINESS STUDIES.  
TIME: 1 ½ HOURS**

**Instructions.**

**Answer all questions in the spaces provided.**

1. State four characteristics of basic wants.  
(4mks)

2. Classify each of the following production activities as either Primary, Secondary or Tertiary. (4mks)

<b>Activity</b>	<b>Level of production</b>
Constructing a bridge	
Transporting medicines	
Growing vegetables	
Making tea	

3. Name four commercial services which are useful to a manufacturer.  
(4mks)

4. State the type of utility created in each of the following cases. (4mks)

- i. There is exchange hence one is able to acquire what they do have.
- ii. Goods are stored until when they are needed.
- iii. Goods are taken to where they are required.
- iv. Converting goods to the right shapes and sizes required.

5. Highlight four characteristics of Direct production.  
(4mks)
6. What are the payments for the following factors of production.  
(4mks)
- i. Labour
  - ii. Capital
  - iii. Enterprenuer
  - iv. Land
7. State four disadvantages of Division of labour and specialization.  
(4mks)
8. State four functions of an entrepreneur. (4mks)
9. Apart from shows and exhibitions list four other sources of business ideas.  
(4mks)

10. Highlight four reasons why a business needs a business plan.  
(4mks)

11. State four ways of classifying goods and services produced in an economy.  
(4mks)

12. Name four duties carried out in an office.  
(4mks)

13. Highlight four characteristics of a good filing system. (4mks)

14. List four roles of filing in an office.  
(4mks)

15. List three types of office layouts.

(3mks)

16. Name the office equipment used to perform each of the following tasks.

(4mks)

- a. Printing stamp impression on envelopes.
- b. Cutting paper into required sizes
- c. Pinning papers together
- d. Recording, processing, sorting and retrieving information.

17. State four factors to be considered when selecting office equipment.

(4mks)

18. State essential qualities of an office staff.

(3mks)

Name..... Adm. No.....

Date ..... Class: .....

FORM ONE  
END OF TERM EXAMS  
COMPUTER STUDIES

Instructions to candidates

*Answer all questions.*

*All answers must be written in English.*

*Drawings to be drawn using a pencil.*

FOR EXAMINERS USE ONLY

MAXIMUM SCORE	CANDIDATE'S SCORE
<b>80</b>	

1. a. Define the following terms as used in ICT. (4 Marks)

i. Data.

.....  
.....

ii. Data processing

.....  
.....

iii. Information

.....  
.....

b. Clearly illustrate the two types of system units. (4 Marks)

2. a. Give three characteristics of First Generation Computers. (3 Marks)

.....



b. complete the table below about the mechanical tools that were considered to be the earliest computers. (5 Marks)

Tool	Application area	developer
Abacus	.....	.....
Napier Borne	.....	.....
Analytical Engine	.....	Charles Babbage

3. State the technology used in each of the following computers. (5 Marks)

i. 1<sup>st</sup> Generation Computers

.....  
 .....

ii. 2<sup>nd</sup> Generation Computers

.....  
 .....

iii. 3<sup>rd</sup> Generation Computers

.....  
 .....

iv. 4<sup>th</sup> Generation Computers

.....  
 .....

v. 5<sup>th</sup> Generation Computers

.....  
 .....

4. List the different types of computers when classified according to the following.

a. According to physical size. (4 Marks)

.....

b. According to functionality.

(3 Marks)

c. According to purpose.

(2 Marks)

5. Study the keyboard below and use it to answer questions.

(5 marks)



- A: .....
- B: .....
- C: .....
- E: .....
- F: .....

b. Mention three types of keyboards that may be used to enter data into a computer. (3 Marks)

6. Name the following types of mouse.

(3 Marks)



.....  
a.



.....  
b.



.....  
7. Explain how computers are used in the following areas.

a. Supermarket

(2 Marks)

.....  
.....  
.....

b. Banks.

(2 Marks)

.....  
.....  
.....

8. Explain the following components that make up a computer system.

(6

Marks)

i. Hardware

.....  
.....

ii. Software

.....  
.....

iii. Liveware

.....  
.....

9. a. Define a computer laboratory.

(2 Marks)

.....

.....  
b. give five factors to consider when preparing a computer laboratory. (4 Marks)

.....  
.....  
.....  
.....  
.....

c. Give five rules to observe when entering a computer laboratory. (5 Marks)

.....  
.....  
.....  
.....  
.....

d. Give three causes of fire in the computer laboratory. (3 Marks)

.....  
.....  
.....

e. Why are powder and liquid fire extinguishers discouraged in the computer laboratory? (2 Marks)

.....  
.....  
.....

f. Give three precautions that prevent dust from entering the computer laboratory and damaging the computers. (3 Marks)

.....  
.....  
.....

10. Write the following abbreviations in full. (3 Marks)

- i. POST: .....
- ii. BIOS: .....
- iii. UPS: .....

11. State three functions of a Uninterruptable Power Supply in a computer laboratory. (4 Marks)

.....  
.....  
.....  
.....

12. What is booting? (1 Mark)

.....  
.....

13. Give two types of booting. (2 Marks)

.....  
.....

THIS IS THE LAST PRINTED PAGE.  
GOOD LUCK

NAME: ..... ADM NO: ..... CLASS: .....  
101  
ENGLISH  
FORM ONE  
END OF TERM 1 EXAM – 2021  
TIME: 2 HOURS

**Answer all the questions in the spaces provided.**

**SECTION 1**  
**FUNCTIONAL WRITING (20 MARKS)**

Write a letter to your mother informing her how you are doing at school after reporting back.

**SECTION 2**  
**COMPREHENSION: (20 MARKS)**

Read the passage below and answer the questions that follow.

**BATTLE AT THE MANDAZI KIOSK**

There was a nasty fight at the shopping centre this morning. I watched it all and I thought it was rather silly and sad. I mean, why should two grown-up human beings fight in public, like cockerels, over a little matter which they can settle through a simple discussion. Anyway, it all started with Mwakawago, the bicycle mechanic, going up to Amina’s kiosk and ordering two mandazi. He gave Amina fifty shillings and she gave him the mandazi. When Mwakawago asked for his change, Amina told him there was no change. Mwakawago could not believe his ears. He knew that mandazi cost twenty shillings each, and he expected change of ten shillings from his fifty shillings

“What do you mean?” he asked Amina.

“The price has gone up to twenty-five shillings each,” said Amina simply.

“When did you raise the price? Why didn’t you tell us?” asked Mwakawago angrily.

“Well, I am telling Iyo now,; retorted Amina. “Where would I find the time to go telling every Ali, Cheronon and Oyango about price changes?”

“Why didn’t you put up a public notice? You thief,; bellowed Mwakawago fiercely,  
“You went rob me in broad daylight”

:“I’m not a thief,” Amina reiterated.

“Maybe your mother is”

“What did you say?” asked Mwakawago, his voice thick with threat.

Amina tightened the knot on the *leso* round her hips, looked Mwakawago straight in the eye and said, “You have no right to come here and call me a thief when I am just going about my business. If you do not want my mandazi, just give them back and take your lousy money”

“And where does my mother come in?” asked Mwakawago furiously.

“Go and ask her,” Amina shouted back.

Flying into a rage, Mwakawago threw the mandazi straight into Amina’s face. Then he grabbed her by the front of her blouse and pulled her from behind the low table on which her basket of mandazi sat. In the struggle they upset the table, and the basket and mandazi scattered in the dust all over the road. Mwakawago slapped Amina twice, spitting a stream of insults at her at the same time.

Just then Amina gave Mwakawago three sharp kicks on the shins and he reeled back, yelling in pain and letting go of Amina’s blouse. Amina picked up a pot of boiling oil and aimed it at Mwakawago. Luckily it missed him. Then Amina grabbed a knife and dashed at Mwakawago, who had picked up a huge stone and was threatening to hurl it at her.

Fortunately, a small crowd of neighbours who had gathered around the combatants restrained them just in time. Mama Kivumbi, the vegetable seller got hold of Amina and tried to calm her down. Mwakawago was held back by Simiyu from the carpentry workshop and Maneno, the barber. Amina and Mwakawago kept yelling insults at each other. Eventually, Karimi, the chairperson of the market Traders’ Association, was called. She asked everyone to be quiet so that they could resolve the conflict in a reasonable manner.

“First,” Said Karimi, “how did this whole thing begin?”

It was, however, not easy to get a clear picture of what exactly had happened. Amina

insisted that Mwakawago had attacked her without any provocation, Mwakawago, on the other hand, just kept saying that Amina had insulted his mother, and tried to cheat him.

In a short time, the crowd of traders and other bystanders was divided into two groups. One group supported Mwakawago and said that Amina was in the wrong. She had provoked Mwakawago, especially by insulting his mother. The other group, however, argued that it was Mwakawago who was at fault. He had no business going round slapping innocent traders in their kiosks and scattering their mandazi on the road. Karimi listened patiently to the arguments from each side.

After a while she said, 'I am glad we are all discussing this matter rationally. Maybe if Amina and Mwakawago had talked over their differences, this unfortunate fight need not have taken place.'

"Madam," said Simiyu, "these two were tearing at each other like wild cats. I think they should both be disciplined"

"That may be important, Simiyu," answered Karimi, "but I think reconciliation and an amicable understanding is what Amina and Mwakawago need most now:.

Finally, it was agreed that Karimi and a few fellow traders would help Amina and Mwakawago resolve their differences in the privacy of Karimi's shop. As Amina, Mwakawago and the team of peacemakers headed for Karimi's shop, the crowd dispersed.

### **QUESTIONS:**

1. What does Mwakawago do for a living? (2 mks)
2. Explain in one sentence why Mwakawago does not get the change he expected.(2



mks)

3. Point out one way in which Amina could have informed her customers about the price increase. (2 mks)

4. Give two rude remarks which Amina makes to Mwakawago. (2 mks)

5. Why do you think Amina tightens the knot on the lesa around her hips? (2 mks)

6. How would you describe the personality of Mwakawago? (2 mks)

7. What does Amina do that portray her as a violent person? (2 mks)

8. Explain how the crowd reacted to Amina and Mwakawago's fight. (2 mks)

9. Identify and explain one use of a simile in the passage. (2 mks)

10. Explain the meaning of the following phrases as used in the passage: (2mks)

(i) every Ali, Cheronono and Onyango –

(ii) going about my business -

### **SECTION 3:**

#### **CLOZE TEST (10 MARKS)**

**Fill in the blank spaces in the excerpt below**

Since caning was \_1\_\_\_\_\_ from our schools, many teachers feel like their hands are \_2\_\_\_\_\_ and they just watch as things grow from bad to worse. Some \_3\_\_\_\_\_ have taken advantage of this situation and they feel they can do anything and get \_4\_\_\_\_\_ with it because there are no consequences for their behavior.

It is very important to \_5\_\_\_\_\_ open communication between teachers, students and school administration. This can help the teachers know and understand what is going on with their students.

There are schools that have \_6\_\_\_\_\_ boxes that students use to write about the issues that need attention. If there is a \_7\_\_\_\_\_ relationship between teachers and students that is \_\_8\_\_\_\_\_ by genuineness, trustworthy, empathy and understanding, then the students will \_\_9\_\_\_\_\_ free to speak out their fears, and concerns. Some of the incidents that we have witnessed are a way of students crying out for \_10\_\_\_\_\_

### **SECTION 4:**

#### **ORAL SKILLS (5 MARKS)**

**Identify the silent letter in the following words:**

1. Debt –

2. Write –

3. Psalm –

4. Ghost –
5. Dormitory –

**SECTION 5:**  
**GRAMMAR**

**(a) Fill in the gaps in the following sentences using a suitable collective noun. (4 mks)**

1. He is the leader of the \_\_\_\_\_ that was terrorizing the villagers.
2. The driver gave me a \_\_\_\_\_ of boys.
3. The groom came with a \_\_\_\_\_ of cars.
4. It is advisable to travel in a \_\_\_\_\_ while in remote places.

**(b) Fill in the blanks using the plural forms of the words in brackets. (6 mks)**

1. He bought \_\_\_\_\_ at the market (axe)
2. There were many \_\_\_\_\_ in the granary (mouse)
3. We were asked to bring two \_\_\_\_\_ each. (knife)
4. We share all our \_\_\_\_\_ in school equally (duty)
5. All his \_\_\_\_\_ died during the dry season (sheep)
6. My neighbor keeps a flock of \_\_\_\_\_ in his compound. (goose)

**(c) Give one word that is pronounced the same as the ones below.**

1. Won –

2. March -

3. Heir -

4. Fowl -

5. Tea -

**GEOGRAPHY FORM I, END OF TERM 2 -2021. TIME 1HR 45 MINUTES**

***Answer all the questions in the spaces provided***

**NAME..... CLASS .....ADM.....**

1. a) Name two branches of Geography. (2mks)

b) What is the relationship between Geography and Mathematics? (2mks)

2. The diagram below represents the internal structure of the earth. Use it to answer question a)

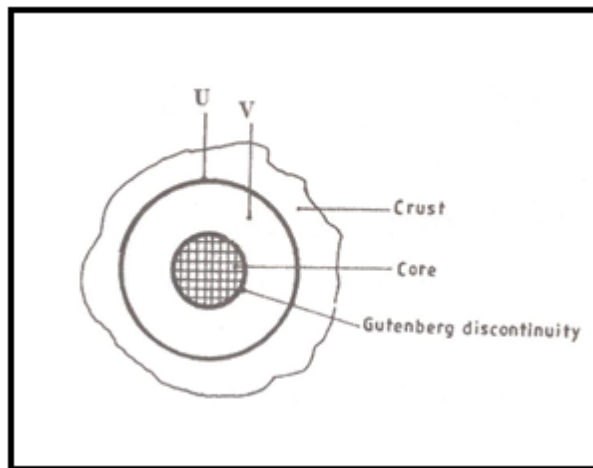

a) Name the parts marked U and V. (2mks)

b) Describe the composition of the

i) Crust.

(4mks)

ii) Core.

(4mks)

3. a) i) Describe the solar system.

(2mks)

ii) The local time at manual  $60^{\circ}\text{W}$  is 11.30am. What is the time in Nairobi  $37^{\circ}\text{E}$ . (3mks)

b) Give five proofs that the earth is spherical. (5mks)

c) State two effects of the rotation of the earth. (2mks)

4. a) i) Define the term weather. (2mks)

ii) Explain how the following factors influence weather

- Cloud cover.

(4mks)

- Local winds.

(4mks)

The diagram below represents a weather measuring instrument. Use it to answer question (b)

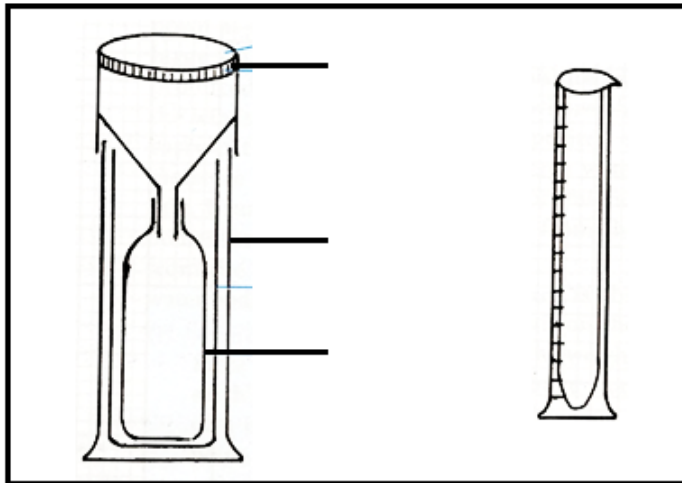

b) Which element of weather is measured using the instrument shown above? (1mk)

ii) Describe how the instrument is used.

(3mks)



c) The table below shows the temperature and rainfall readings for station T in one week. Use it to answer question (c)

Day	Mon	Tue	Wed	Thu	Fri	Sat	Sun
Temperature °C	23	23	24	21	25	25	23
Rainfall in mm	50	49	49	45	60	60	49

c) i) Calculate:

The range of temperature for the week. (1mk)

The mean weekly rainfall. (2mks)

ii) State four benefits of weather forecasting. (4mks)

d) Give four characteristics of the stratosphere. (4mks)

5. Suppose your class carried out a field study on weather around your school environment;

i) Give four methods the class used to collect data in the field. (4mks)

ii) State three advantages of studying weather through fieldwork. (3mks)

iii) State three problems likely to be encountered during fieldwork. (3mks)

6. a) Give three types of maps. (3mks)

b) State any two uses of maps. (2mks)

c) i) Name two types of scales. (2mks)

ii) Give the uses of scales in a map.

(2mks)

NAME.....CLASS.....ADM.....  
HOMESCIENCE  
FORM ONE  
END TERM 2 2020  
TIME: 1 ½ HOURS

Answer all the questions in the spaces provided.

1. Define the following terms.

(i) Hygiene.

(1mk)

(ii) First aid.

(1mk)

2. Name two parts of the skin.

(2mks)

3. Suggest two methods on how to avoid athlete feet .  
(2mks)

4. What are accessories?

(1mks)

5. Differentiate between the following

(a) Scalds and burns.

(2mks)

(b) Sprain and fractures.

(2mks)

(c) Cuts and bruises.

(2mks)

6. Suggest three importance of housing a family.  
(2mks)

7. Suggest one precaution to take when cleaning china cups. (1mk)
8. List three methods of providing family with shelter. (3mks)
9. State two classification of dirt. (2mks)
10. List three qualities of a good duster. (3mks)
11. Name any two kitchen plan. (2mks)
12. State two advantages of suction method in removing of loose dirt. (2mks)
13. State two areas of the house referred as wet areas. (2mks)
14. State three methods of removing loose dirt. (3mks)
15. List two problems related to the feet. (5mks)

16. State two factors one should observe when caring for hair.  
(2mks)

17. What is the use of a mackintosh spread before sheets in a bed.  
(2mks)

18. What causes fainting. (1mk)

19. Name four improvised cleaning materials. (2mks)

20. List down five types of brushes commonly found in the home.  
(5mks)

21. Suggest the name of an opening in a wall between the kitchen and the dining room.  
Suggest its function.  
(2mks)

22. Define good grooming.

(1mk)

**SECTION B:**

**Attempt all questions.**

23. You have been asked to stay at home and carry out some household chores

(a) Describe how you will thoroughly clean the bathroom.

(7mks)

(b) Clean the refrigerator.

(8mks)

(c) Clean stainless steel equipment.

(5mks)

NAME:.....CLASS:.....ADM NO:.....  
MATHEMATICS  
FORM ONE  
END TERM 2 EXAM  
TIME: 2 HOURS

Instructions.

Answer all questions in the spaces provided.

1. Express the following numbers in words. (2mks)

a) 14633001

b) 30000010

2. A matatu charges sh. 120 as fare from town A to town B. It has a capacity of 18 passengers. How much money does it make in one day covering 10 trips with full capacity. (3mks)

3. Use the divisibility test of 11 to check whether the following numbers are divisible by 11.

(2mks)

a) 1048564



b) 1120043

4. Use Bodmas to evaluate.

(3mks)

$$\frac{1}{2} \left[ \frac{3}{5} + \frac{1}{4} \left( \frac{7}{3} - \frac{3}{7} \right) \text{ of } 1 \frac{1}{2} \div 5 \right]$$

---

$$3 \frac{5}{7}$$

5. Victoria spent  $\frac{1}{4}$  of his net January salary on school fees. She spent  $\frac{1}{4}$  of the remainder on electricity and water bills. She then spent  $\frac{1}{9}$  of what was left on transport. If she finally had sh. 3400. What was her net January salary.

(3mks)

6. Using mathematical tables evaluate.

a)  $7340^2$  (1mk)

b)  $14.5^2 + 0.714^2$   
(2mks)

7. Given that  $a:b = 1:2$  and  $b:c = 3:4$ . Find  $a:b:c$  (1mk)

8. Three bells ring at intervals 30mins, 35mins and 50 mins. If they ring together at 11:25 p.m on Monday at what time and day will they next ring together?  
(3mks)

9. The length of minute hand of a clock is 3.5cm. Find the angle it turns through if it sweeps an area of  $4.8\text{cm}^2$ . (take  $\pi = \frac{22}{7}$ ) (3mks)

10. Express the following as a single fraction.

a)  $\frac{x-1}{2} + \frac{x+2}{4} + \frac{x}{5}$  (3mks)

b) 
$$\frac{ax - ay + bx - by}{a+b}$$

(2mks)

11. Fifteen tractors each working eight hours a day takes eight days to plough a piece of land. How long would it take 24 tractors each working 10 hours a day to plough the same piece of land.

(3mks)

12. Use factor tree to decompose 256 into prime factors.

(2mks)

13. Juma, Ali and Hassan share the profit of their business in the ratios 3:7:9 respectively. If Juma receives sh. 6000. How much profit did the business yield.

(3mks)

14. Use bodmas to evaluate:

(4mks)

$$\frac{5 \times 6 - 76 \div 4 + 27 \div 3}{4 - 2 \times 4 + 36 \div 4}$$

$$4 - 2 \times 4 + 36 \div 4$$

15. A Kenyan bank buys and sells foreign currency as shown in the table below.

	Buying (ksh)	Selling (ksh)
1 us dollar	95.34	95.87
1 uk pound	124.65	125.13

A tourist arrived in Kenya with 15000 pounds which he converted in kshs.

a. How much kshs did he receive?

(2mks)

b. He later spend sh. 125340 while in Kenya. He converted the remainder in dollars. How many dollars did he receive?

(3mks)

16. A metallic cuboid measuring 16cm by 8cm by 4cm was melted. The material was used to make a cube. What is the length of the cube.

(3mks)

17. Find a if  $a^2 = b^2 + c^2$  given that  $b=2$   $c=3.5$ .  
(2mks)

18. Below is a travel timetable for a vehicle operating between towns A and D 70 km apart.

Town	Arrival	Departure
A		10.10 am
B	10.30am	10.40 am
C	11.00 am	11.05 am
D	11.20am	

- a. At what time does the vehicle depart from town A?  
(1mk)
  
- b. How long does it take to travel from town A to town B?  
(1mk)
  
- c. For how long does it stay in town B?  
(1mk)
  
- d. At what time does it arrive in town D? (1mk)
  
- e. What is the average speed of the whole journey?

(3mks)

- f. A football match lasts 90 minutes with a break of 15 minutes at half time. If a referee allows five minutes extra for injuries and stoppages, what time does a match which kicks off at 4:30 pm end?  
(3mks)

19. A rectangular plot measures 100m by 200m. Determine:

- a. Its perimeter in km. (2mks)
- b. Its area in  $m^2$ .  
(2mks)
- c. Its area in ha. (2mks)

d. Square tiles of 100cm by 100cm are used to cover the floor. How many tiles are used?  
(2mks)

e. If the cost of 1 tile is sh. 25. How much money will be spent on tiles.  
(2mks)

NAME: ..... ADM. NO: .....CLASS.....

END OF TERM 2, 2021  
232 PHYSICS  
FORM 1  
TIME: 1 HOUR 45 MINS

**INSTRUCTIONS TO CANDIDATES:**

- Write your name, admission number and class in the spaces provided above.
- The paper consist of two Sections A and B. Answer all the questions in the spaces provided.
- Mathematical tables may be used.

**FOR EXAMINER'S USE ONLY:**

SECTION	MAXIMUM SCORE	CANDIDATE'S SCORE
A	40	
B	30	

TOTAL SCORE

**SECTION A - (40 MARKS)**

1. Define the term physics. (1 mark)
  
2. State **three** career opportunities related to physics. (3 marks)
  
3. The table **below** shows some basic quantities and their SI units. Complete the table to show the missing entries. (2 marks)

	Quantity	S.I unit	Symbols
1		Candela	
2	Amount of substances		



4. A stone of mass, 40g was completely immersed in a liquid. The levels of the liquids are shown in the figure.

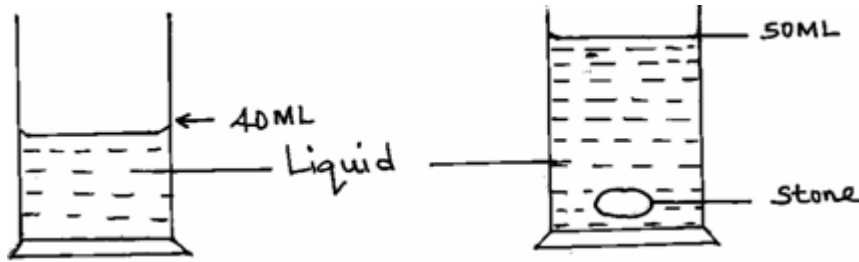

Determine the density of the stone in SI unit. (2 marks)

5. (a) One of the factors that affect surface tension is temperature of the liquid. State one other factor. (1 mark)

- (b) Use surface molecules A, B, C and inner molecule D shown below, to explain why surface of a liquid is under tension. (2 marks)

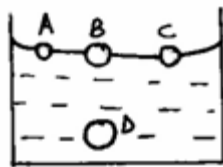

6. Name two forces that determine the shape of a liquid drop on a solid surface. (2 marks)

7.  $1800\text{cm}^3$  of fresh water of density  $1000\text{kg/m}^3$  is mixed with  $2200\text{cm}^3$  of sea water of density  $1025\text{kg/m}^3$ . Calculate the density of the mixture

(4mks)

8. State the reason why it may not be possible to suck a liquid in to your mouth using a drinking straw in the surface of the moon. (1 mark)

9. In building construction, beams made of concrete are reinforced with steel. Explain. (2 marks)

10. When a liquid is heated in a glass flask, its level first falls and then rises. Explain this observation. (2 marks)

11. Name the thermometric liquid that is most suitable to use in very cold places. (1 mark)

12. (a) State **one** factor which makes gases compressible. (1 mark)

(b) The figure **below** shows a set up used to demonstrate Brownian motion in gases.

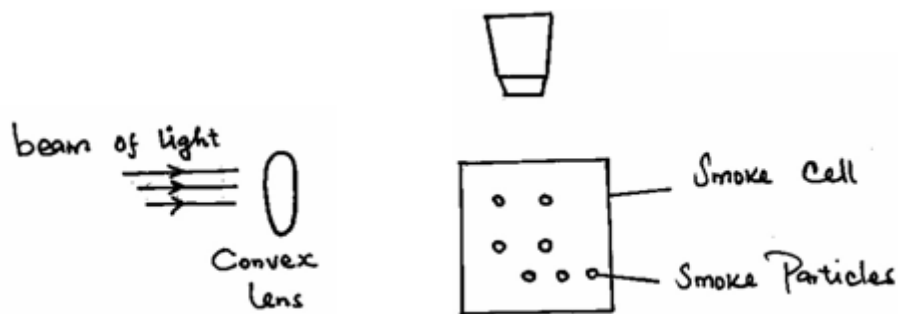

State the role of the;

(3 marks)

(i) Convex lens.

(ii) Microscope.

(iii) Beam of light.

(c) Define the term diffusion.

(1 mark)

13. Highlight **two** factors which shows that heat from the sun does reach the earth surface by convection.

(2 marks)

14. The figure **below** shows some wax at the end of a copper rod.

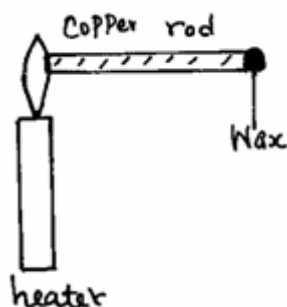

State **three** factors that affect the rate at which the wax melts.  
(3 marks)

(3 marks)

15. (a) Define force and give its S.I units

(2mks)

(b) State **three** effects of force on an object

(3mks)

(c) Name and show forces acting on a box placed on a table.

(2mks)

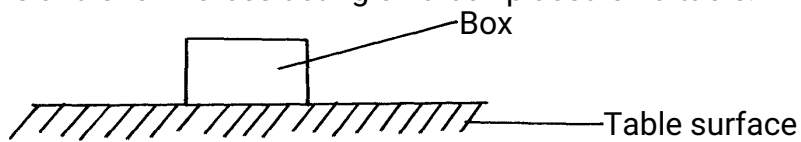

**SECTION B - (30 MARKS)**

16. A ream of foolscaps containing 500 papers has a thickness of 50mm and a mass of 2kg. if it has a width of 200mm and a length of 300mm, find;

a) The thickness of one sheet of paper (2 marks)

b) The mass of one sheet of paper (2 marks)

c) The volume of one sheet of paper

(3 marks)

d) The density of the paper.

(3 marks)

8

17. (a) **Two** identical aluminium rods shown in the figure **below** are heated by the same Bunsen burner. One rests on a metal block and the other on a wooden block.

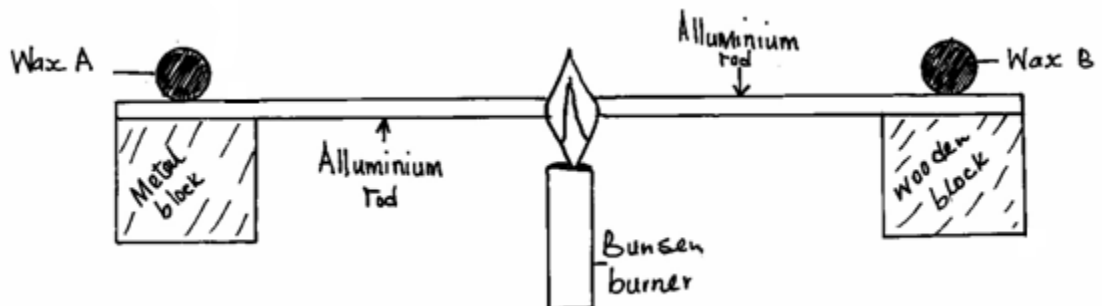

State with a reason which wax is likely to melt.

(2 marks)

- (b) Two identical cans **A** and **B** were each filled with hot water at the same temperature and covered with an air tight lid as shown **below**.

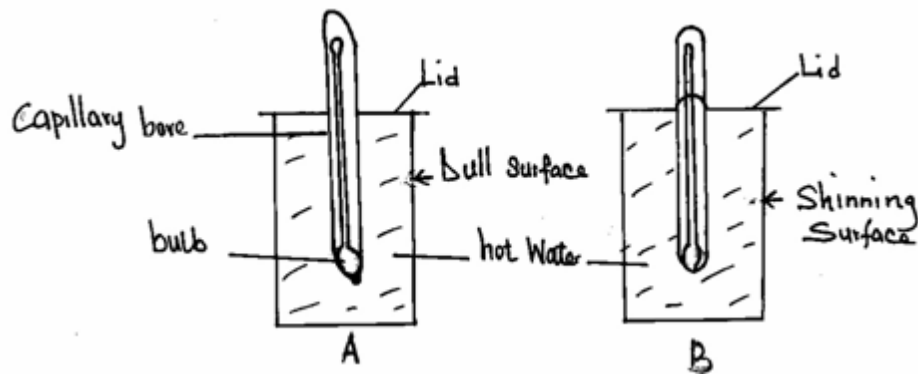

Given that the outer surface of can **A** is dull while that of **B** is shiny, state with a reason which thermometer would show lower temperature after ten minutes. (2 marks)

- (c) State the purpose of the following features of a thermometer. (3 marks)

(i) Narrow capillary bore.

(ii) Thin bulb.

(iii) Thick glass stem.

- (c) State **three** properties of mercury that makes it a good thermometric liquid. (3 marks)

18. States the reason why it is not correct to quote the weight of solid objects in kilograms. (1 mk)
19. Wasike found that the width of his desk was approximately 10 palm-lengths. If his palm was 15.0cm long,  
what was the width of his desk in metres? (3 mks)
20. Describe how to estimate the height of a tree using a rod of about 2m long and a tape measure.(3 mks)
21. The mass of an empty density bottle is 20g its mass when filled with water is 40.0g and 50.0 when filled  
with liquid x. Calculate the density of liquid X if the density of water is  $1000\text{kgm}^{-3}$ . (3 mks)







12. State three Clans among the taita in Kenya (3mks)

13. Give the factors that led to migration of bantus from Congo basin (6mks)

14. Outline way in which archaeology located archaeological sites (5mks)

15. Give the effects of food shortage in Africa (6mks)

**Section B: Answer all questions in this section**

16. (a) State five factors that suggests that Africa is the cradle land for mankind. (5mks)

(b) Explain five factors that have contributed to food shortage in Africa.

17. (a) Name five groups that belong to Eastern Cushites. (3mks)

(b) Describe the political organization of Somali during the Pre – colonial period. (12mks)



JINA: .....NAMBARI: ..... KIDATO: .....

**KISWAHILI KIDATO CHA KWANZA  
MTIHANI WA MWISHO WA MUHULA WA PILI  
MACHI MWAKA 2021**

**UFAHAMU ( ALAM 15)**

Rita na Evelyn walikuwa marafiki wa chanda na pete kwa muda mrefu. Waliishi katika mtaa wa Kibokoni jijini Mombasa. Evelyn alikuwa mwanafunzi wa masomo ya uhazili katika chuo kimoja pale mjini. Naye Rita alifanya kazi ya ukarani papo hapo mjini. Waliishi kidugu katika chumba kimoja walichopanga pale mtaani.

Ingawa marafiki hawa walishirikiana kwa kila njia katika shughuli za upishi, kupiga deki, kufagia, kufua na kazi nyinginezo za nyumbani, aliyekuwa akitoa msaada mkubwa zaidi alikuwa ni Rita. Rita alikuwa na mazoea ya kutunza pesa zake vyema. Aidha alijua maana ya haba na haba hujaza kibaba. Alijua kuwa Evelyn, kama mwanafunzi, hakuwa na uwezo wa kuyakidhi baadhi ya mahitaji yake. Alijitolea sabili hata kumnunulia Evelyn nguo, viatu na vim vingine alivyohitaji. Mara nyingine ilibidi Rita kulipa kodi ya nyumba peke yake kwa vile mwenzake hangeweza kupata pesa kwa wakati. Hakuwahi hata siku moja kumkera wala kumtesa Evelyn kwa jinsi yoyote ile. Fauka ya hayo, hakuwahi kumsemesha vibaya wala kuonyesha dharau kwake. Aliamini kama wanavyosema watu kuwa dunia rangi rangile, huenda siku moja atahitaji kusaidiwa yeye pia. Siku kama hiyo atamtegemea Evelyn, mwandani wake.

Evelyn alipomaliza masomo yake alikuwa na bahati ya mtende. Alipata kazi nzuri mara moja katika kampuni moja ya maffita papo hapo jijini. Lakini muda si muda, mambo ya ajabu yalianza kutokea. Baada ya kupata kazi yenye kipato kizuri, kichwa cha Evelyn kilianza kufura mfano wa kaimati. Badala ya kunisaidia mwenzake katika kazi za pale nyumbani pamoja na gharama za maisha, alifhatilia raha za jijini kwa kuamini ule msemu wa ponda raha kufa kwaja. Rita alipomwuliza alimjibu kwa ukali, "Nikusaidie nini? Sasa si kama wakati nilipokuwa mwanafunzi. Kila mtu ana pesa zake. Ala!"

Rita hakumwelewa tena Evelyn. Isistoshe, alianza kumwibia Rita vitu vyake wakati alipokuwa hayupo nyubani. Mara kwa mara Rita aligundua kuwa pesa alizokuwa ameficha sehemu Fulani nyumbani zimedokolewa. Alipomwuliza, Evelyn alikujajuu, "Unafikiri mimi sina pesa? Unadhani ni wewe tu uliyeajiriwa?" Rita alizidi kushangaa, Muda wote alioishi na kumfadhili rafiki yake aliamini kuwa atamlipa mema. "Kumbe fadhila za punda ni mateke?" Alijiuliza Rita. Baada ya muda, urafiki wao ulivunjika na Evelyn akahamia mtaa wa Furaha alikoendelea na maisha yake ya starehe na ureda.

Hata hivyo mambo yalianza kumwendea mruma Evelyn. Wakubwa wake kazini hawakupendezwa najinsi alivyoendesha shughuli zake pale ofisini. Mara nyingi alifika kazini akiwa amechelewa na

kila wakati alitoa vijisababu mbalimbali ambavyo havikumridhisha yeyote. Aidha, alipokuwa ofisini hakufanya mengi isipokuwa kutembea kutoka ofisi hii hadi nyingine akiwasumbua watu kazini mwao. Mara kwa mara alionekana akisinzia wakati wenzake walipokuwa wakichapa kazi. Lakini lililowakera zaidi wakuu wa kampuni hiyo ya mafuta ni jambo fulani lililoanza kutendeka pale. Vitu vya watu vilianza kupoteapotea. Mara mfanyikazi huyu anapoteza saa yake, mara mwingine anapoteza pesa, mara hiki mara kile. Wakuu walipoyatupa mawazo yao nyuma wakagundua kuwa mambo haya yalianza kutendeka mara tu alipowasili Evelyn. Wakaamua kumwekea mtogo. Evelyn alioshikwa kimasomaso akidokoa mkoba wa msichana mwenzake. Mkoba huo ulikuwa umeaehwa juu ya dawati kimakusudi ili kumvuta Evelyn. Evelyn alifutwa kazi papo hapo. Fauka ya hayo, alitiwa mikononi na kukabidhiwa poisi waliomtupa korokoroni. Kesho yake Evelyn alifikishwa mahakamani na kushtakiwa kwa kosa la wizi. Alitozwa faini ya shilingi elfu tano au kifungo cha miezi sita. Hakuwa na pesa zozote za kulipia faini hii. Akawekwa rumande. Hata rafiki mmoja hakuwa naye wa kumuauni katika wakati huo wa majaribu. Kwa bahati, Rita alisikia kuhusu kadhia hiyo. Hakupoteza muda. Akashika njia moja kwa moja hadi kituo cha polisi. Mpango ukafanywa na akamlipia. Evelyn ile faini. Evelyn alipoachiliwa hum akashangaa. "Yaani nimesamehewa ama nini?" Aliuliza. "La. Hujasamehewa. Faini uliyotozwa imelipwa na msichana yule." Evelyn akageuka na kumwona Rita. Alimtazama kwa muda bila kujua la kusema. Mwishowe alimsogea kisha wakakaribiana polepole na kukumbatiana. Machozi yakaanza kumdongoka Evelyn, nde! Nde! Nde! Akalia kilio cha uchungu na soni. Akamwomba Rita msamaha, "Nisamehe, sikujua nililokuwa nikifanya. Nilidhani kuwa baada ya kupata kazi sitahitaji tena urafiki wako. Haya yalipata yamenifunza," alisema kwa masikitiko. "Evelyn, kijengacho mtu ni uth na tabia," alisema Rita. "Ni kweli rafiki yangu" alitamka Evelyn, Sasa nimejitia kwenye shida. Hata kazi yangu nzuri nimeipoteza. Sina mahali pa kuishi. Itabidi nirudi kijijini kwa baba na mama. Kwaheri rafiki yangu naasante kwa yote uliyofanya." "La! Hutaondoka". Rita alimwambia lcwa dhati, "Tutakwenda nawe nyumbani mwangu tukaishi pamoja kama zamani. Nitayagharamia mahitaji yako yote hadi utakapopata kazi".

Basi Rita na Evelyn wakaungana tena na kuishi vizuri katika nyumba ile ile mtaani Kibokoni. Kweli akufaaye kwa dhiki ndiye rafiki.

MASWALI:

1. Maisha ya Evelyn na Rita yalikuwaje kabla ya Evelyn kupata kazi? (alama 2)

---

2. Kutokana na jinsi Rita alivyomtunza Evelyn, unafikiri yeye alikuwa ni mtu wa ama gani?

(alama 2)

---



---

3. Eleza baadhi ya mambo ambayo Rita alimtendea mwenzake. (alama 2)

---



---

4. Baada ya kupata kazi Evelyn alikuwa mtu mkarimu. Je, unakubali? Eleza ilivyokuwa. (alama 2)

---



---

5. Evelyn alipokuwa mwanafunzi hakuwa na tabia ya udokozi. Unafikiri ni kwa nini alianza tabia hiyo baada ya kuajiriwa? (alama 2)

---



---

6. 'Asiyefunza na mama hufunzwa na ulimwengu.' Methali hii inahusianaje na Evelyn? (alama 1)

---

7. 'Akufaaye kiwa dhiki ndiye rafiki.' Methali hii inahusianaje na Rita? (alama 1)

---

8. Eleza maana ya misemo ifuatayo kama ilivyotumika kwenye kifungu: (alama 3)

(a) marafiki wa chanda na pete

---



---

(b) enda mrama

---



---

(c) jitolea sabili

---



---

### **SARUFI NA MATUMIZI YA LUGHA (ALAMA 35)**

1. Pambanua sauti hizi kama ni ghuna au sighuna. (al 2)

(i) /t/

(ii) /g/



2. Kamilisha methali zifuatazo; (al 2)

- (i) Mgaagaa na upwa \_\_\_\_\_  
 (ii) Mvumilivu\_\_\_\_\_

3. Andika visawe vya ; (al 2)

(i) Janibu

(ii) Jadi

4. Tunga sentensi zenye maneno yafuatayo; (al 3)

(i) N + V + T

(ii) N + V + T + E

(iii) I + N + T

5. Onyesha viambishi awali na tamati katika sentensi hizi; (al 2)

(i) Alimkaribisha

(ii) Umeogelea

6. Onyesha matumizi manne ya koma. (al 4)

7. Maneno yafuatayo yako katika ngeli gani? (al 3)

(i) Mchungwa

(ii) Mdudu

(iii) Bonde

8. Andika sentensi zifuatazo katika umoja. (al 3)

(i) Nyavu zimechanikachanika

(ii) Nyuzi ziliingia matata

(iii) Fito zilikatwakatwa

9. Andika wingi wa; (al 3)

(i) Kiganja

(ii) Cheo

(iii) Kibindo

10. Geuza sentensi zifuatazo ziwe katika wakati ujao. (al 2)

(i) Mimi ninapenda mtoto mtiifu.

(ii) Ninyi mnapendwa na wenzenu.

11. Geuza sentensi zifuatazo ziwe katika hali timilifu. (al 2)

(i) Safari hii itakuwa ndefu

(ii) Shamba letu linalimwa

12. Tunga sentensi ukitumia vitenzi hivi katika hali ya kutendewa. (al 2)

(i) Kata

(ii) Pasua

13. Eleza maana ya kirai. (al 1)

14. Onyesha kundi Nomino na kikundi tenzi katika sentensi hii. (al 2)

Hatibu hupaswa kuifahamu lugha

15. Tegua vitendawili vifuatavyo. (al 2)

Kisima kidogo kimejaa changararwe

Namsikia lakini simwoni

**ISIMU JAMII (AI 10)**

- (i) Eleza maana ya sajili ya shuleni. (al 2)
  
- (ii) Taja sifa nane za sajili ya shuleni. (al 8)

**FASIHI SIMULIZI AL 10**

- 1. (a) Fafanua maana ya ; (al 2)
  - (i) Fasihi andishi
  
  - (ii) Fasihi simulizi
  
- (b) Onyesha tofauti zilizopo kati ya fasihi andishi na fasihi simulizi. (al 8)