

# F1 MIDTERM 3 EXAMS

## ALL SUBJECTS

*Dear Students, Attempt These Midterm Exams!*

For Marking Schemes Call 0705525657

NAME: ..... ADM NO ..... CLASS.....

### 231 BIOLOGY

## FORM 1 MIDTERM 3 EXAMS

TIME: 2HRS

### INSTRUCTIONS TO CANDIDATES:

- Answer **ALL** the questions
  - Answers should be written in the spaces provided
1. i) State **one** process that takes place during the light stage and **one** that takes place in the dark stage of photosynthesis. (2mks)
- Light stage;.....
- Dark stage;.....
- ii) Name three products of the light stage of photosynthesis (3mks)
- .....
- .....
- .....
- .....
- c) Name **three** types of cells in the leaves where photosynthesis occurs (3mks)
- .....
- .....
- .....
- .....

2. Name **one** example of the specialized cells in plants and one example in animals.

(i)Plants

(1mk)

.....  
.....

(ii) Animals

(1mk)

.....  
.....

3. Identify the following apparatus and state its functions.

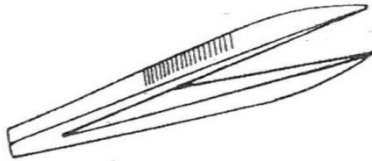

i) Name.....(1mk)

ii) Function (1mk)

.....  
.....

4. A student measured the length of a mitochondrion on a photomicrograph whose magnification was X 40000 and found it to be 1mm. Calculate the actual size of the mitochondrion. (3mks)

5. State the type of solution that makes the plant cell. (2mks)

i) Flaccid.....

ii) Turgid.....

6. Name the carbohydrate stored in:

i) Cell wall. .... (1mk)

ii) Mammalian liver. .... (1mk)

7. Name the monosaccharides that make up the disaccharides below

a) Sucrose.....(1mk)

b) Lactose.....(1mk)

c) Maltose.....(1mk)

8. (a) Name **three** characteristics of living organisms (3mks)

**FOR MARKING SCHEMES CALL/TEXT/WHATSAPP 0705525657**

.....  
.....  
.....  
.....

(b) Apart from Plantae and Animalia, name **three** other kingdoms. (3mks)

.....  
.....  
.....

9. Draw a well labeled diagram show the external parts of a simple leaf (6mks)

10. **Give two** characteristics that distinguish scientific names from common names. (2mks)

.....  
.....  
.....

11. (a) **What** is cell specialization (1mk)

.....  
.....  
.....

(b) Name **three** types of tissues found in animals (3mks)

.....  
.....  
.....

(c) Name **three** main types of lenses found on a light microscope (3mks)

.....  
.....  
.....

12. The diagram below represents the digestive system in man. Study the diagram and answer the questions that follow

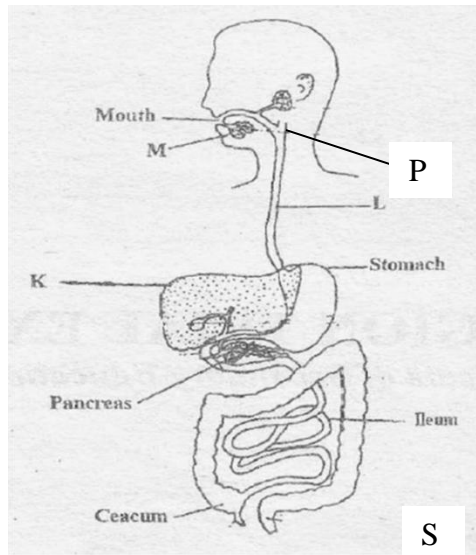

(a) Label the part K ,L, S and salivary glands M and P (5mks)

K ..... L.....  
 S' ..... M.....  
 P.....

(b) Name **three** hormones which are secreted along the alimentary canal (3mks)

.....  
 .....  
 .....

13. List down **four** differences between a light microscope and an electron microscope (4mks)

Light Microscope	Electron Microscope

14. List down **four** factors that determines energy requirements in human being: (4mks)

.....  
.....  
.....  
.....

15. Define the following branches of Biology. (2mks)

i) Genetics

.....  
.....  
.....

ii) Entomology

.....  
.....  
.....

16. State the functions of each of the following organelles.

a) Nucleolus (1mk)

.....  
.....

b) Golgi apparatus (2mks)

.....  
.....  
.....

17. The diagram below represents a longitudinal section of a human tooth.

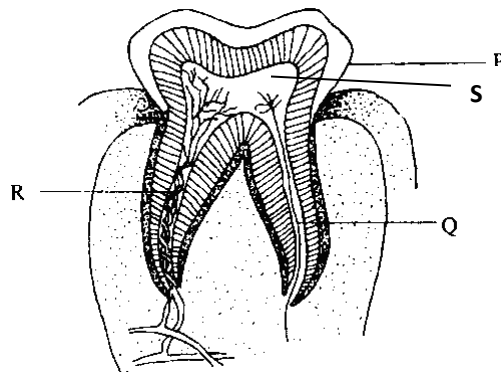

(a) Identify the type of tooth. (1mk)

.....  
.....  
(b) Give one reason for your answer in (a) above.

(1mk)

.....  
.....  
(c) State one function of the tooth.

(1mk)

.....  
.....  
(d) State the function of the part labeled Q

(1mk)

.....  
.....  
e) Name the parts labeled P, Q, R, and S

(3mks)

P.....

Q.....

R.....

S.....

# FORM 1 MIDTERM 3 EXAMS ENGLISH

NAME .....ADM NO ..... FORM.....

**Cloze Test, Oral Skills, Comprehension and Grammar**

**INSTRUCTIONS:**

**QUESTION 1: CLOZE TEST**

**(10MARKS)**

**Fill in the blanks with most appropriate word.**

What is good governance? This is a (1).....that people discuss very often. It refers to the responsible management (2)..... the affairs of a village, town or country. Where there is good (3)..... people live in harmony, ways of alleviating poverty are sought (4).....people assume ownership of 5.....process of developing their communities.

Although the government is (6).....to create a conducive political and legal (7)..... for development, it cannot succeed if ordinary citizens do not co-operate and (8).....their role. Everyone craves for maintenance of the rule of (9).....but if we do not (10).....that very law, we will not know peace

**QUESTION 2: ORAL SKILLS (5MARKS)**

**a) Identify the silent letters in the words below**

**(3mks)**

- i) Doubt.....
- ii) Science.....
- iii) Biscuit .....

**b) For each of the following words, write another word that is pronounced in the same way**

**(2mks)**

- (a) Air.....
- (b) Night .....

**QUESTION 3: COMPREHENSION (15MARKS)**

**Read the following passage and answer the questions that follow:-**

**FOR MARKING SCHEMES CALL/TEXT/WHATSAPP 0705525657**

**SCHOOL BULLIES.**

I still remember - my hands and my finger - tips still remember; what used to lie in store for us on our return to school from the holidays. The guava trees in the school yard would be in full leaf again, and the old leaves would be strewn around in scattered heaps. In places there were even more than just heaps of them: it would be a muddy sea of leaves.

“Get all that swept! The headmaster would tell us. “I want the whole place cleaned up, at once!”

“At once!” There was enough work there. Damned hard work, too to last us for over a week. Especially since the only tools with which we were provided were our hands, our fingers, our nails.

“Now see that it’s done properly, and be quick about it, “the headmaster would say to the older pupils, “or you’ll have to answer for it”.

So at an order from the older boys, we would all line up like peasants about to reap or clean a field, and we would set to work like members of chain-gang. In the school yard itself, it wasn’t too bad: the guava trees were fairly well spaced; but there was one place where the closely planted trees grew in a hopeless tangle of leaves and branches,

The sun could not penetrate here, and the acrid stench of decay linger in the undergrowth even at the height of the summer.

If the work was not going as quickly as the headmaster expected, the big boys instead of giving us a helping hand, used to find it simpler to whip us with branches pulled from the trees. Now guava wood is regrettably flexible; skillfully handled, the springing switches used to whistle piercingly, and fall like flails of fire on our backsides. Our flesh stung and smarted, while tears of anguish sprang from our eyes and splashed on the rotting leaves at our feet.

In order to avoid these blows, we used to bribe our tyrants with the succulent cakes of Indian Corn, the conchios made of meat and fish which we used to bring for our daily midday meal. And if we happened to have any money on us, the coins changed hands once. If we did not do this, if we were afraid of going home with an empty stomach or an empty purse, the blows would be redoubled. They were administered with such furious generosity and with such diabolical gusto that even a deaf man would have gathered that we were being flogged not so much to spur us on to work, but rather to lash us into a state of submissiveness in which we would be only too glad to give up our food and money.

Occasionally, one of us, worn out by such calculated cruelty would have the courage to complain to the headmaster. He would of course be very angry, but the punishment he inflicted on the older boys was always negligible - nothing compared to what they had done to us. And the fact is that however much we complained our situation did not improve in the slightest. Perhaps we should have let our parents know what was going on, but somehow we never dreamed of doing so; I don’t know whether it was loyalty or pride that kept us silent, but I can see now that we were foolish to keep quiet, for such beatings were utterly foreign to our nature, and completely at variance with our passion for independence and equality.

**Questions.**

1. Why was the school yard in a very untidy condition? (1mks)

.....  
.....  
.....

2. How did the Headmaster make sure that the work was done properly. (2mks)



3. Why was it pointless to complain to the Headmaster about the bullying. (2mks)

4. How did the boys avoid blows from the bullies? (2mks)

5. Why didn't the younger boys complain to their parents about the bullying? (2mks)

6. Who do you think was most to blame for the bullying? (2mks)

7. If you were one of the young boys, what would you have done? (1mks)

Define the following words as used in the passage. (3mks)

a) Negligible: .....

b) Strewn:.....

c) Splashed:.....

**QUESTION 4: GRAMMAR (20MARKS)**

**a) Choose the correct form of the pronoun in each of the following sentences. 3mks**

(i) Kinya and (**she, her**) work in a media house.

(ii) I read the report he wrote to Murna and (**I, me**).

(iii) She is more responsible than (**they, them**)

b) Fill in the blank spaces in the following sentences using either a, an or the where necessary.

(5mks)

1. Miss Judith is ..... secondary school teacher
2. James was ..... best swimmer in the world
3. She knows how to play ..... football
4. He wants to climb ..... Ruwenzori mountains
5. .... Rich are always the losers

c) Write the following sentences in their plural form.

(2mks)

- (i) Peter had quite some luggage to carry.

.....

- (ii) The hoof of the horse hurt the goose.

.....

d) Arrange the following words in the order you expect to find them in the dictionary.

(1mk)

Orbit, occupy, observe, ornament, obtain, oncology, optician.

e) Fill in the passage with appropriate prepositions

(5mks)

When I was a little girl, i used to look..... life as an easy thing. .... the earl  
80's my days were filled ..... lots of play, laughter and sleeping. As I grew ..... an adul  
life started taking a u-turn. Now, my days are full.....hardwork, worries and sleepless nights.

f) Punctuate the following sentences correctly.

(2mks)

- i. I don't know how to swim he explained
- ii. masiga says here is a game this morning.

(g) Fill in the blank spaces with the correct form of adjectives in the bracket.

- (i) John is the \_\_\_\_\_ of the three brothers . (old)

- (ii) Which is the \_\_\_\_\_ fashion in the market? (late)

g) Fill in the blank spaces with one of the given words in brackets.

(2mks)

- i) Roy is the .....member of this movement. (oldest / eldest)
- ii) Most Kenyans were eager to hear the ..... news from their president ( latest / last)

# FORM 1 MIDTERM 3 EXAMS

NAME: ..... ADM. NO: .....CLASS:....

## AGRICULTURE

1. Give four factors entailed in agriculture as an art. (2mks)
2. Differentiate between olericulture and pomoculture. (2mks)
3. Name four methods of farming. (2mks)
4. State four ways by which agriculture contributes to national development.(4mks)
5. State four factors that lead to low crop production. (2mks)
6. Name four biotic factors influencing agricultural production negatively.(2mks)

**FOR MARKING SCHEMES CALL/TEXT/WHATSAPP 0705525657**

7. State four effects of high temperature on crop production. (4mks)

8. Name three forms in which soil water exists. (1 ½ mks)

9. List four physical weathering agents in the soil formation process. (2mks)

10. The diagram below represents farm tools and equipments. Study them and answer the questions that follow.

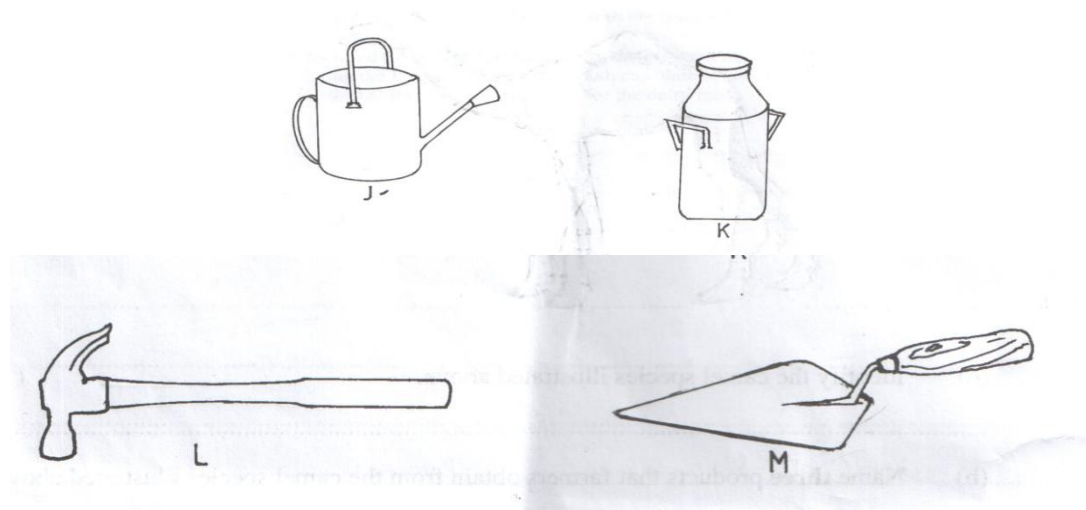

a. Identify the tool / equipment J, K and M. (1 ½ mks)

J –

**FOR MARKING SCHEMES CALL/TEXT/WHATSAPP 0705525657**

K –

M –

b. State one use for each of the tool/equipment labeled K and L. (2mks)

K

L

c. Give two maintenance practices for the equipment labeled K. (2mks)

11.State four maintenance practices of a jack plane. (2mks)

12. Name four complementary tools and equipments. (2mks)

13. State the correct use of each of the following tools. (2mks)

a. Tin snip

b. Cold chisel

14. State four reasons for proper care and maintenance of farm tools and equipments. (2mks)

15. State four factors that influence the number of secondary cultivation done.  
(2mks)

16. State four reasons for ridging. (2mks)

17. State four practices that encourage minimum tillage. (2mks)

18. Below is a diagram showing a method of drainage. Use it to answer questions that follow.

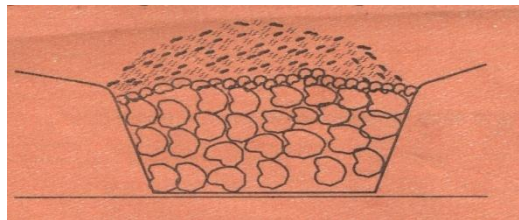

a. Identify the method. ( ½ mks)

b. Other than the above method name three other methods used in drainage.  
(1 ½ mks)

**FOR MARKING SCHEMES CALL/TEXT/WHATSAPP 0705525657**

- c. Outline four reasons for draining farm land. (2mks)
19. Name three non-chemical methods of water treatment. (1 ½ mks)
20. State four advantages of trickle irrigation. (2mks)
21. State three types of pipes used in conveying water on the farm. (1 ½ mks)
22. Give four factors considered when selecting site for compost manure preparation. (2mks)
23. Give four indicators of well-decomposed manure. (2mks)

24. Name two methods that are used in preparing compost manure. (1mk)
- b. Give four reasons for limited use of organic manures to small scale crop production. (2mks)
25. State four importances of livestock. (2mks)
26. Name a sheep breed which is resistant to foot rot disease. ( ½ mk)
- b. Mention any two examples of meat goats in Kenya. (1mk)
- c. Give the terms used to describe the following livestock of different age, sex, etc
- i. Mature male pig ( ½ mk)
- ii. Sterilized birds ( ½ mk)
- iii. Mature female goat ( ½ mk)
- iv. Young one of a sheep ( ½ mk)
27. Name three dual purpose breeds of cattle. ( 1 ½ mks)



b. Name the two species of camel. (1mk)

28. State five uses of farm records. (5mks)

# FORM 1 MIDTERM 3 EXAMS

## BUSINESS STUDIES

NAME .....ADM.....CLASS.....

1. State **four** disadvantages of division of labour. (4 marks)

.....  
.....  
.....  
.....  
.....  
.....  
.....  
.....

2. Outline four ways in which a good business structure is of benefit to a business organization.. (4 marks)

.....  
.....  
.....  
.....  
.....  
.....  
.....  
.....

3. Outline **four** difficulties faced in the satisfaction of human wants. (4marks)

.....  
.....  
.....  
.....  
.....  
.....

**FOR MARKING SCHEMES CALL/TEXT/WHATSAPP 0705525657**

4. Apart from the use of computers in offices, outline other **four** current trends in office management. (4marks)

.....

.....

.....

.....

.....

.....

.....

.....

.....

5. Highlight four reasons for making choices between competing wants. (4mks)

.....

.....

.....

.....

.....

.....

.....

.....

.....

6. Identify weather the following factors form the external or internal environment(4mks)

Factors	External	Internal
a) Political climate		
b) Size of population		

c) Goals and objectives		
d) Employees		

7. Mention four advantages of departmental filing system. (4mks)

.....

.....

.....

.....

.....

.....

.....

.....

8. Highlight four barriers to entrepreneurial development. (4mks)

.....

.....

.....

.....

.....

.....

.....

.....

9. Define the following terms as used in Business Studies. (4 mks)

(i) Economics

.....

.....

(ii) Entrepreneurship

.....

.....



.....  
.....  
.....  
.....

14.State the term given to each of the following disciplines (4 marks)

a) Study of how man strives to satisfy his unlimited wants using the limited resources

.....  
.....

b) Study of the process of identifying a business opportunity and acquiring resources to start and operate a business

.....  
.....

c) Study of trade and aids to trade

.....  
.....

d) Refers to a systematic way of recording business activities which are used for decision making.

.....  
.....

15.Highlight four reasons for making choices between competing wants (4 marks)

.....  
.....  
.....  
.....  
.....  
.....  
.....

16. POA a serious entrepreneur has identified a business opportunity in one of the towns in Kenya and wants to borrow money from Faulu bank. State four factors he has to take into consideration before he borrows the money (4 marks)

.....  
.....

.....

.....

.....

.....

.....

.....

17. Classify the following resources as either renewable or non renewable wood, coal, soda ash, building stones, stove, wool, silk and iron. (4 marks)

Renewable	Non-renewable
i)	
ii)	
iii)	
iv)	

18. State four circumstances under which photocopying may be used to reproduce documents in a school (4 marks)

.....

.....

.....

.....

.....

.....

# FORM 1 MIDTERM 3 EXAMS

NAME: ..... ADM NO: ..... CLASS: .....

TIME: 1 ½ HOURS

Answer all the questions in the spaces provided.

1. What is Chemistry? (1 mk)
2. Give three advantages of studying Chemistry. (3 mks)
3. Give the functions of the following laboratory apparatus. (5 mks)
- (i) Crucible –
  - (ii) Desicator –
  - (iii) Dropping funnel –
  - (iv) Thistle funnel –
  - (v) Tongs -
4. Define the following terms: (4 mks)
- (i) Drug –
  - (ii) Drug abuse –
  - (iii) Prescription –
  - (iv) Indicator –
5. Give the differences between luminous flame and non-luminous flame. (5 mks)

Luminous	Non-luminous
(i)	
(ii)	
(iii)	
(iv)	
(v)	

**FOR MARKING SCHEMES CALL/TEXT/WHATSAPP 0705525657**



6. (a) After use, a non-luminous flame should be put off or adjusted to a luminous flame. Explain. (2 mks)
- (b) State any 6 safety rules in the laboratory. (6 mks)
7. Name three substances that undergo sublimation. (3 mks)
8. Give the methods that can be used to separate the following mixtures:- (3 mks)
- (i) Iron filings and sulphur.
  - (ii) Sodium chloride and aluminium chloride.
  - (iii) Common salt and water
9. (a) What is fractional distillation? (1 mk)
- (b) Give two applications of fractional distillation. (2 mks)
10. The diagram below shows a chromatogram obtained when spots of pigments X, Y and a mixture of Z were placed on an absorbent material and allowed to dry. The paper was then dipped in a solvent and results obtained as shown below.

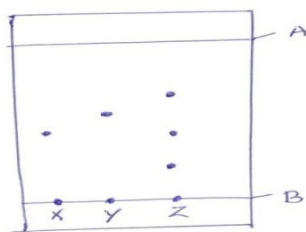

- (a) Name A and B. (2 mks)
- (b) Which pure pigment was a component of Z. (1 mk)
- (c) What are the factors that determine the distance moved by the spots? (2 mks)
- (d) Why is water not used as a solvent? (1 mk)
11. Give the names of the compounds formed by the following elements: (3 mks)
- (a) Carbon and oxygen
- (b) Sodium and sulphur.
- (c) Sodium, carbon and oxygen.
12. Complete the following word equations:- (4 mks)
- (a) Sodium carbonate + dilute sulphuric acid
- (b) Sodium + water
- (c) Sodium hydrogen carbonate + dilute hydrochloric acid
- (c) Magnesium + Dilute hydrochloric acid
13. Give two differences between acids and bases. (2 mks)
- |     | Acids | Bases |
|-----|-------|-------|
| (a) |       |       |
| (b) |       |       |
14. Give two uses of bases. (2 mks)

15. The diagram below shows the fractional distillation of liquefied air. Study it and answer the questions that follow.

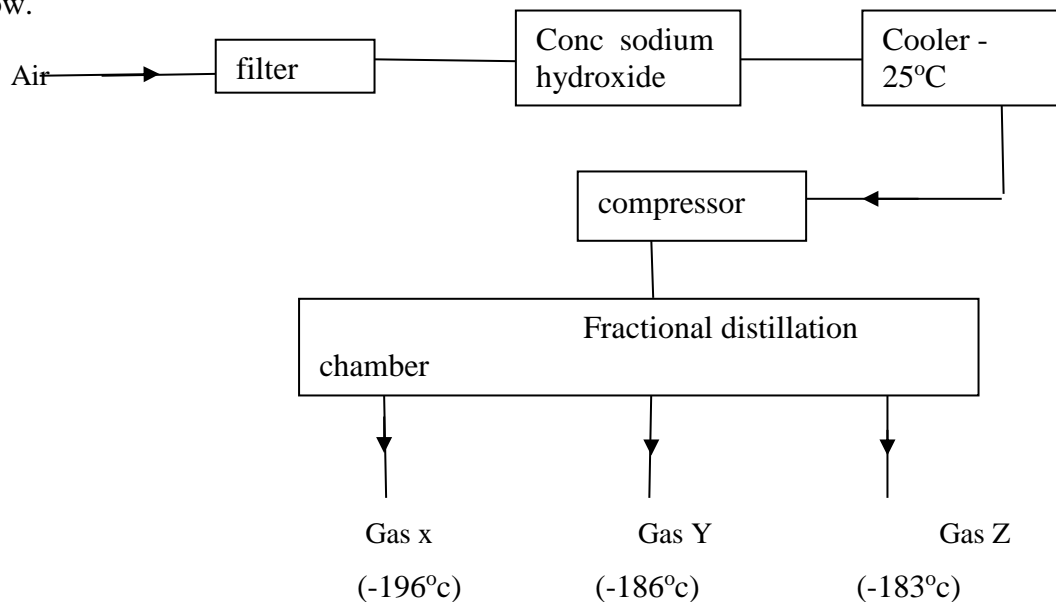

- a) Name the substances removed in the filtration chamber. (1mk)
- b) Name gases X, Y and Z. (3mks)

16. The diagram below show laboratory preparation of Oxygen gas.

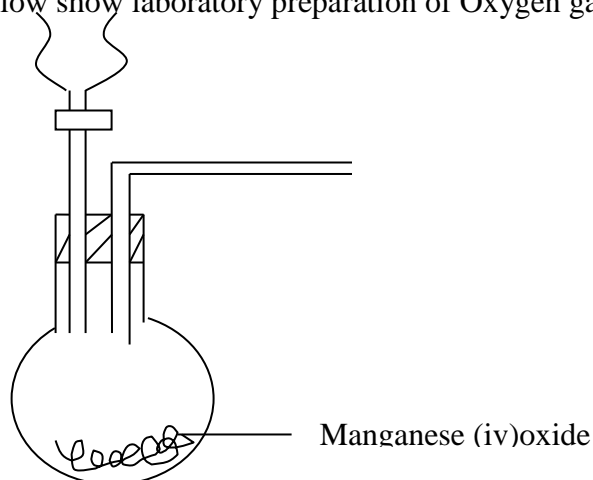

- a) Complete the gas to show how oxygen gas is collected. (2mks)
- b) Why is oxygen gas collected as shown above. (1mk)

c) Write a word equation for the equation of the reaction occurring above. (1mk)

d) Give 3 uses of oxygen gas. (3mks)

17. With the help of word equations identify the products of heating candle wax. (3mks)

18. Name the following methods of gas collection (3mks)

Gas P

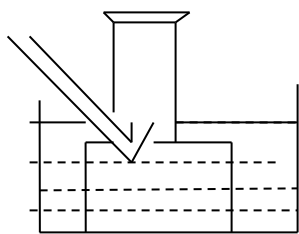

(i)

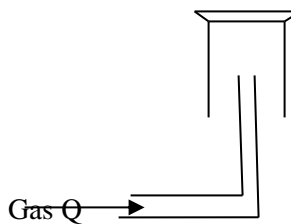

(ii)

Gas R

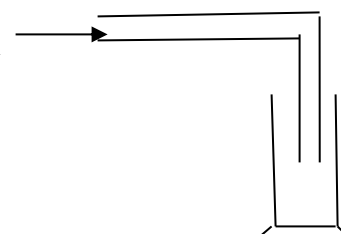

(iii)

19. Give 2 uses of hydrogen gas. (2mks)



.....  
.....

(b) State six importance of the Temple to the Israelites. (6mks)

.....  
.....  
.....  
.....  
.....  
.....  
.....

3. (a) With reference to Genesis 12:1-9, outline seven promises given to Abraham by God at the time of his call. (7mks)

.....  
.....  
.....  
.....  
.....  
.....  
.....  
.....  
.....  
.....  
.....

(b) List five attributes of God learnt from the ten plagues. (5mks)

.....  
.....  
.....  
.....  
.....  
.....  
.....







.....  
.....  
.....  
.....  
.....

(b) Identify five groups of people who were referred to as specialists in traditional societies.  
(5mks)

.....  
.....  
.....  
.....  
.....  
.....  
.....  
.....  
.....

# FORM 1 MIDTERM 3 EXAMS

311/2

## HISTORY AND GOVERNMENT

NAME: .....ADM NO: .....CLASS: .....

1. Identify **five** sources of Kenyan history.
2. Name **four** sub-clans of the mijikenda. (4mks)
3. State **two** natural factors which facilitated the coming of the early visitors to the Kenyan coast before 1500AD.(2mks)
4. Name **one** Portuguese commander who led in the Portuguese expedition to the East African Coast. (1mk)
5. Identify **three** peaceful method of conflict resolution in Kenya. (3mks)
6. Describe the political organization of the Kamba during the pre-colonial period (10mks)

**FOR MARKING SCHEMES CALL/TEXT/WHATSAPP 0705525657**



10. State **six** benefits of fire to early man.(6mks)

11. Highlight **seven** freedoms and rights of Kenyan citizens.(7mks)

12. State **eight** factors that undermine national intergration.(8mks)



# FORM 1 MIDTERM 3 EXAMS

## GEOGRAPY

NAME.....ADM.....CLASS.....

1. Apart from rainfall name three other forms of precipitation. (3mks)

.....  
.....  
.....  
.....

2. Give two ways in which latitude influences the temperature of a place. (2mks)

.....  
.....  
.....  
.....

3. What is temperature inversion? (2mks)

.....  
.....  
.....  
.....

4. Use the diagram below to answer the questions that follow

Identify seasons in position A and D. (2mks)

.....  
.....  
.....  
.....

i) How long did it take the earth to move from position D to C? (2mks)

.....  
.....

**FOR MARKING SCHEMES CALL/TEXT/WHATSAPP 0705525657**



.....  
 .....  
 .....

DIAGRAM

The diagram above shows the occurrence of petroleum in the earth crust.

a) Name the substance in the areas labeled L, M and N. (3mks)

.....  
 .....  
 .....  
 .....

b) Give two by-products obtained from the refining of crude oil. (2mks)

.....  
 .....  
 .....  
 .....

7. a) Name two minerals mined using nanning methods. (2mks)

.....  
 .....  
 .....  
 .....

c) State two problems associated with shaft mining. (2mks)

.....  
 .....  
 .....  
 .....

8. i) Draw a compound bar graph to represent the data below. Use a scale of 1cm represent 10 thousand tones. (8mks)

EAST AFRICA BEEF EXPORT IN 000' TONES FROM 1998 – 2001

COUNTRY	1998	1999	2000	2001
KENYA	30	40	36	25
UGANDA	20	25	27	54
TAZANIA	30	60	65	124

**FOR MARKING SCHEMES CALL/TEXT/WHATSAPP 0705525657**



ii) State two limitation of compound bar graph in represent data. (2mks)

.....  
.....  
.....  
.....

iii) State three differences between beef exports in Kenya and Tanzania. (3mks)

.....  
.....  
.....  
.....

iv) Which year had the highest export of beef and by how many tones in the three countries? (2mks)

.....  
.....  
.....

9. What is an isothermal layers. (2mks)

.....  
.....

10. Indentify two planets that rotate from the east to the west. (2mks)

.....  
.....  
.....

11. Name three types of scales. (3mks)

.....  
.....  
.....  
.....

12. Name five marginal information in a topographical map. (5mks)

.....  
.....  
.....  
.....  
.....  
.....  
.....  
.....  
.....

13. Name three main type of field work. (3mks)

.....  
.....

.....  
.....  
.....  
14. Name five negative effects on the environment during the exploitation of minerals. (5mks)

.....  
.....  
.....  
.....  
.....  
.....  
.....  
.....  
.....  
.....  
.....

# FORM 1 MIDTERM 3 EXAMS

## KISWAHILI MUHULA WA TATU KISWAHILI KIDATO CHA KWANZA Saa: 2½

JINA: .....NAMBARI: .....DARASA.....

### MAAGIZO

- (a) Jibu maswali yote katika; Ufahamu, Ushairi, Matumizi ya lugha, fasihi simulizi na Isimujamii.  
(b) Andika majibu yako katika nafasi uliyopewa

### SEHEMU A: UFAHAMU (ALAMA 15)

*Soma kifungu kifuatacho kisha ujibu maswali.*

*Jukwaani chini kulia kuna mlango wa kutokea. Linapofunguka pazia, Mama Tatu anaonekana akisuka ukili. Anaelekea mlango wa kutokea nje. Mlango wa kuingilia ndani upo upande wake wa kulia.*

**Mama:** (Anamtazama bila kupendezewa). Anasema huku anasuka ukili) Hmm. Hiyo kanzu imezidi tena. Si unatembea uchi hivyo. Fupi, fupi, imekubana. Ndio uambiwe nini? Mzungu sana!

**Tatu:** Mama, watoto wote wanavaa hivi hivi siku hizi (Ananung'unika).

**Mama:** Hm. Haya sisi yetu macho tu. Maana husikizi tena. Umekuwa mkubwa, siwezi kukupiga. Basi haya fanya utakavyo tu. (Kimya).

**Tatu:** Maa. (Kwa hofu kidogo).

**Mama:**Sema tu, nakusikia.

**Tatu:** (Ahema) Nataka ruhusa kwenda sinema.

**Mama:**Sinema gani?

**Tatu:** Empress.

**Mama:**Basi si bado? Leo ndio kwanza Ijumaa, "Lady Show" Jumapili.

**Tatu:** Nataka kwenda leo usiku.

**Mama:** Toka lini ukaenda sinema usiku? Siku zote unakwenda Jumapili mchana. Mchana sikukatazi, lakini usiku hapana, hapana, hata kidogo. Kwanza pesa za kukupa wewe kila Jumapili ziko wapi? Baba yako hali yake unaijua. Kila siku hapa analalamika kodi zimekuwa nyingi. Nawe unamsikia. Kodi ya kichwa, kodi ya miguu, kodi ya uzee, kodi ya mapato, kodi ya wafanyakazi, kodi, kodi, iiee! Nawe unataka sinema. Pesa zenyewe ziko wapi?

**Tatu:** Mie sitaki pesa mama, nipe ruhusa tu. Swai atanichukua sinema. (Ma Tatu ameshtuka.Anamtazama Tatu. Anarudia kusuka ukili wake).

**FOR MARKING SCHEMES CALL/TEXT/WHATSAPP 0705525657**

(kimya)

**Tatu:** Ma, atakuja sasa hivi. Jee nende? (kimya).

**Mama:**(Polepole) Na huyu Swai ndio nani?

**Tatu:** Mtoto mmoja Swai Hamisi. Najuana naye.

**Mama:** Mwanamume?

**Tatu:** (Anaitika kwa kichwa).

**Mama:** Nae anakuchukua sinema – Na kwa nini yeye akulipie sinema? Anakujuaje? Baba yako?

Au nani? (*Anaacha kusuka*)

(*Kimya*).

**Mama:** (*kwa sauti ya juu*) Nijibu! Wewe unafikiri, anapata taabu hii yote ya kukuchukua sinema kwa nini, eh? Wewe mwana mzima sasa huwezi kufikiria?

**Tatu:** Mama ingekuwa kuna jambo lolote baya tusingetaka ruhusa. Swai ni rafiki tu.

**Mama:** Hakuna urafiki baina ya mtoto wa kiume na mwanamwali hata kidogo. Uwongo.

Usitudanganye.

Hivi unaniona mjinga sana, eh?

**Tatu:** Mama (*kwa sauti ya kubembeleza*) siku hizi watoto wote wanakwenda na marafiki wa kiume kutembea, si kitu geni.

**Mama:** Sio uzungu! Ndio kuiga uzungu tena. Basi sisi si wazungu. Mzungu na Mwafrika mbalimbali. Mila zetu mbalimbali. Wao hawana haya, anaweza kwenda na mume huyu na mume yule

isiwe kitu.

(*Ebrahim Hussein, Michezo ya Kuigiza, Nbi: EAPH, 1980*)

### MASWALI

1. Pendekeza kichwa mwafaka kwa kifungu hiki. (alama 1)

—

2. Taja wahusika **wawili** wa kiume waliorejelewa katika kifungu hiki. (alama 2)

—

3. Taja sababu **nne** zilizomfanya Mama amzuie Tatu kwenda sinema. (alama 4)

—

---

---

---

---

---

- 3) 4. Eleza tofauti kati ya mila za Wazungu na za Waafrika asilia kulingana na kifungu hiki. (alama 3)

---

---

---

---

5. Huku ukitolea mifano kutoka kwenye kifungu, onyesha tabia **tatu** za Tatu. (alama 3)

---

---

---

---

6. Ina maana gani kusema “Haya sisi yetu macho tu”? (alama 2)

---

---

---

**SEHEMU B: SARUFI NA MATUMIZI YA LUGHA (ALAMA 15)**

1. Toa mfano mmoja mmoja kwa kila aina ya konsonanti uliyopewa. (alama 2)

(i) Kipasuo:

---

- (ii)  
Kitambaza: \_\_\_\_\_
2. (a) Taja vipashio vya lugha. (alama 2)
- \_\_\_\_\_

- (b) Rekebisha sentensi hii: Mwalimu ambaye aliyenifunza amekuja. (alama 2)
- \_\_\_\_\_

3. Bainisha viambishi awali, mzizi na viambishi tamati katika maneno yafuatao: (alama 3)

	Viambishi awali	Mzizi	Viambishi tamati
Atakutengenezea			
Wasaidieni			

- 4 Andika sentensi zifuatazo katika ukubwa.
- (i) Wanawake hao waliuza mbuzi wao wote. (alama 1)
- \_\_\_\_\_

- (ii) Kigari chake kiliharibikia katika kibonde chenye kijito. (alama 2)
- \_\_\_\_\_

- 5 Tunga sentensi kuonyesha tofauti ya ki maana kati ya maneno haya. (alama 2)

(a)  
Vua: \_\_\_\_\_

(b) Fua: \_\_\_\_\_

- 6 Utatafuta maneno gani kwenye kamusi, ukitaka kujua maana za maneno yafuatayo. (alama 1)

(a) Kucheza:

\_\_\_\_\_

(a) Usinipige: \_\_\_\_\_

\_\_\_\_\_

### **SEHEMU C: USHAIRI (ALAMA 10)**

#### **Wapenda mtu kwa kitu**

Shairi nakuleteya, tafadhali mwana twaa  
Hikwita hunikimbiya, na kunitiya tama

**FOR MARKING SCHEMES CALL/TEXT/WHATSAPP 0705525657**

Kumbe mebadili niya, hata washenzi watwaa  
Una mahaba tamaa, wapenda mtu kwa kitu.

Nilidhani u libasi, njema ya mtu kuvaa  
Hawa sina wasiwasi, popote ninapokaa  
Kumbe u mtu rakhisi, atakaye hukutwaa  
Una mahaba tama, wapenda mtu kwa kitu.

Usinionye mija, miuja haitafaa  
Kwamba huna nami haja, ukinambia si baa  
Mtu hupenda kimoja, sende nami kwa hadaa  
Una mahaba tama, wapenda mtu kwa kitu.

Umejifunza wekevu, kutaka kunihadaa  
Na huno wako uovu, ni bure hautafaa  
Mimi ni wana mtuvu, sitendwi hataataa  
Una mahaba tama, wapenda mtu kwa kitu.

Kunena mangi nataka, lakini wasaa  
Na hapa tulipofika, ni kheri hakuambaa  
Maana u mtu nyoka, huna ahadi u baa  
Una mahaba tama, wapenda mtu kwa kitu.

Tamati sineni sana, muhibu toa tamaa  
Ulotenda nishaona, wala hutanihadaa  
Sasa kheri kuatana, kulla mtu akaa  
Una mahaba tama, wapenda mtu kwa kitu.  
(Kutoka, Malenga wa Mvita, uk. 163)

### **Maswali**

1. Shairi la mishororo minne katika kila ubeti huitwa? (alama 1)

---

2. Tambua vina katika ubeti wa pili. (alama 2)

---



---



---

3. Eleza maana ya ‘Una mahaba tama, wapenda mtu kwa kitu,’ (alama 2)

---



---

4. Taja mambo **matatu** ambayo msemaji analalamikia katika shairi? (alama 3)

---

---

---

---

5. Maneno yafuatayo yameendelezwa kishairi. Yaandike kwa njia sanifu: (alama 2)

(a) hikwita: \_\_\_\_\_

(b) \_\_\_\_\_ kuatana:

**SEHEMU D: ISIMUJAMII (al.4)**

- (a) Isimu jamii ni nini? (alama 2)

---

- (b) Eleza mambo **mawili** anayozingatia mzungumzaji yeyote ili kutumia lugha inavyofaa. (alama 2)

---

---

**SEHEMU E: FASIHI SIMULIZI (ALAMA 6)**

- (i) Kuna tofauti gani kati ya fasihi simulizi na fasihi andishi. (alama 2)

---

---

---



- (ii) Eleza tofauti mbili kati ya fasihi simulizi na fasihi andishi. (alama 2)

---

- (iii) Eleza tofauti kati ya: (alama 2)

- (a) Hekaya:

---

- (b) Hurafa

---

# FORM 1 MIDTERM 3 EXAMS

NAME: ..... ADM NO: ..... CLASS: .....

## MATHEMATICS

TIME: 2 HOURS

### SECTION I:

Answer all the questions from this section.

1. Use a ruler and a pair of compasses only to construct triangle ABC in which  $AB = 6\text{cm}$ ,  $BC = 8\text{cm}$  and  $\angle ABC = 60^\circ$ . (2 mks)

2. The diagram below shows the net of a solid.

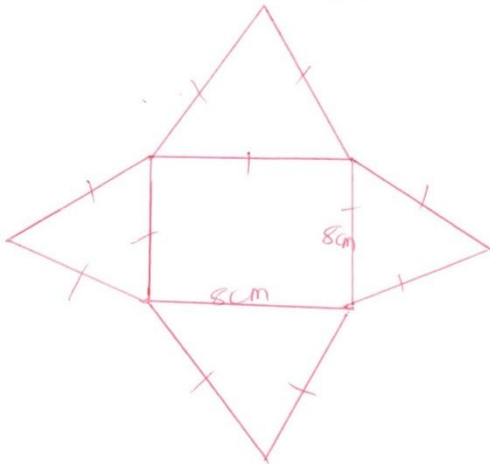

Sketch the solid.

(2 mks)

3. Solve for x in the equation:

(3 mks)

$$\frac{x-2}{5} - \frac{2x-1}{6} = \frac{1-x}{3}$$

**FOR MARKING SCHEMES CALL/TEXT/WHATSAPP 0705525657**

4. Without using a calculator, evaluate;

$$\frac{\frac{5}{8} - \frac{1}{3} \text{ of } \frac{27}{20} \div 2}{1 + (5\frac{2}{5} \div \frac{9}{25})}$$

leaving your answer as a mixed fraction.

(3 mks)

5. Two alloys Y and Z are each made up of zinc, tin and copper. In alloy Y, the ratio of zinc to tin is 2:5 and the ratio of copper to tin is 4:3. Determine the ratio of Copper:Zinc:Tin in alloy Y.(2 mks)

6. In an n-sided polygon, two angles are right angles and each of the remaining angles is  $150^\circ$ . Find the value of n. (3 mks)

7. Given that AB is parallel to DE, calculate  $\angle BCD$ .

(3 mks)

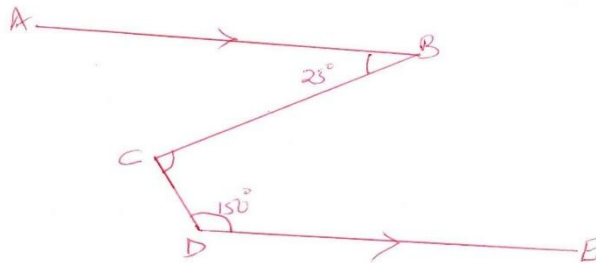

8. The marked price of a car in a dealers shop was 450,000. Wekesa bought the car at 7% discount. The dealer still made a profit of 13%. Calculate the amount of money the dealer had paid for the car.

(3 mks)

9. Food aid 369 880 French Franc was donated to the Turkana drought stricken area. The food was purchased from United states of America (USA) and paid for in US dollars. Calculate the exact value of the food and in dollar if: (1 French Franc = Ksh 12.80 and 1 US dollars = Ksh 84.50) (3mks)

10. During a certain ceremony, goats and chicken were slaughtered. The number of heads (for both chicken and goats) was 45. The total number of legs was 100. Determine the exact number of goats and chicken slaughtered. (3 mks)

11. Using tables, find the square roots of each of the following numbers. (3 mks)  
(a) 0.001952

(b) 952.695

(c) 40

12. Simplify the following expression (3 mks)

**FOR MARKING SCHEMES CALL/TEXT/WHATSAPP 0705525657**

$$\frac{ax-ay+bx-by}{a+b}$$

13. Calculate the area of the shaded region given that the radius is 27cm (4 mks)

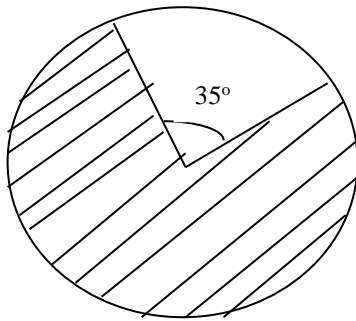

14. Use divisibility test method to test whether the following numbers are divisible by 11.(3 mks)  
(a) 2596

(b) 8151

(c) 4132

**SECTION B:****Answer all the questions.**

15. A surveyor recorded the measurements of a field book using  $XY=360\text{m}$  as the base line as shown below.

	Y	
To E 200	320	
150	210	To D
To F 250	170	150 To C
	50	225 To B
	X	100 To A

a) Use a scale of 1cm to represent 50m to draw the map of the field. (5mks)

b) Find the area of the field in hectares (5mks)

16. Solve the following simultaneous equations using graphical method. (10 mks)

$$2x + y = 7$$

$$2y + 3x = 12$$

**FOR MARKING SCHEMES CALL/TEXT/WHATSAPP 0705525657**

17. Chemilil Sugar Academy hall has 200 seats. During the District Drama Festival, tickets were sold at sh 150 for adult and sh 75 for students
- (a) On day one of the festival, 80% of the seats in the hall were occupied and twenty of the seats were occupied by students. Calculate the total money collected from the sale of tickets this day. (3 mks)

(b) On the last day of the festival X students occupied the seats and all seats were occupied. The money collected from the tickets sales was sh 25,350.

- (i) Write down an equation of X. (2 mks)

- (ii) Calculate the value of X. (2 mks)



(c) The money collected from the sale of tickets during the festival was divided among cost of hosting, allowances for adjudicators and electricity bill in the ratio 7:3:2. If the allowances amounted to 126,000, calculate the;

(i) Amount collected during the festival.

(3 mks)

(ii) The cost of electricity bill during the festival.

(1 mk)

# FORM 1 MIDTERM 3 EXAMS

NAME.....CLASS.....ADM.NO.....

## PHYSICS

1. The figure 1 below shows a measuring cylinder with a fluid to the level shown.

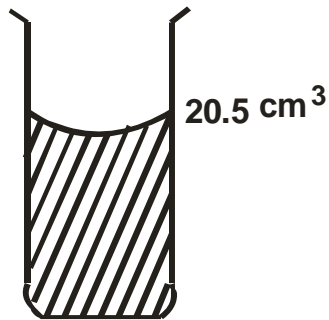

Figure 1

- Find the new level when a solid of mass 13.6g and a density  $1250\text{kgm}^{-3}$  is fully immersed into the cylinder.  
(2 marks)

2. Define current and state its SI units. (2 marks)

3. In a hydraulic press, a force of 200N is applied to a master piston of area  $25\text{cm}^2$ . If the press is designed to produce a force of 5000N, determine;

(a) The area of the slave piston (2mks)

(b) The radius of the slave piston (2mks)

**FOR MARKING SCHEMES CALL/TEXT/WHATSAPP 0705525657**



10. Give a reason why fish can survive under water in a pond even when the surface is frozen. (1mark)
11. Give **one** advantage of alcohol over mercury as a thermometric liquid. (1mark)
12. An object weighs 49N on earth where acceleration due to gravity is 9.8N/kg. Find the acceleration due to gravity on another planet where the same object weighs 40.5N. (2 marks)
13. Give a reason why boiling water cannot be used to sterilize a clinical thermometer. (1 mark)
14. State four factors that affect thermal conductivity. (4 mks)
15. Figure 3 below shows apparatus used to compare the rates of diffusion of gases.

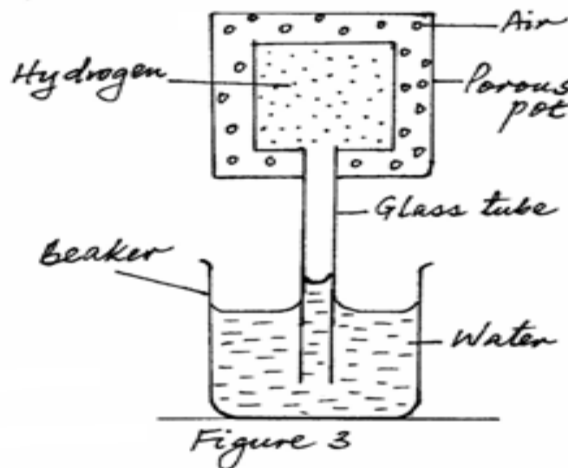

Water is observed to rise up the glass tube. Explain this observation. (2 marks)

16. The mercury column in a barometer is 760mm high. Taking the density of mercury to be  $13.6\text{g/cm}^3$ , calculate the atmospheric pressure in  $\text{N/m}^2$ .(2 marks)

17. a) What is surface tension?

(1 mark)

b) Figure 4 shows a funnel dipped into a liquid soap solution.

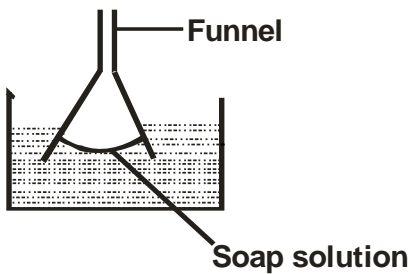

Explain what happens to the soap bubble when the funnel is removed from the soap solution. (2 marks)

18. Figure 7 shows a liquid being siphoned from a beaker to another.

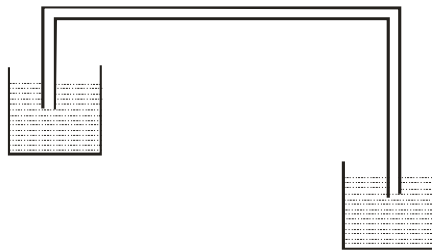

Figure 7

a) Indicate on the diagram the direction of flow of the liquid. (1 mark)

(1 mark)

b) Explain what would happen to the flow of the system if it was put in a vacuum.(2 marks)

19. The diagram below shows a six's maximum/ minimum thermometer.

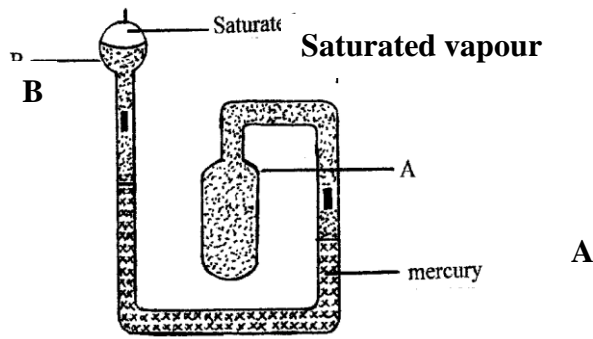

- a) What is the thermometric liquid in this thermometer? (1 mark)  
**Mercury**
- b) Explain how the thermometer indicates maximum and minimum temperature. (4 marks)
- c) Indicate on the diagram the two points where the reading of the temperature shown by the thermometer can be made. (2 marks)

20. The figure below shows a clinical thermometer which is not graduated.

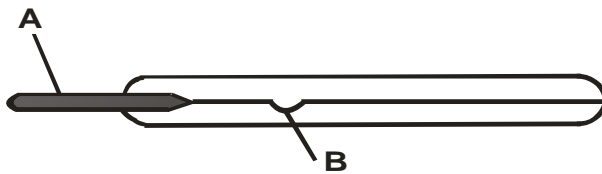

- a) Name the parts indicated with letters A and B. (2 marks)  
 A  
 B
- b) Give the range of the scale for the above thermometer. (1 mark)

21. A mercury barometer reads 760mmHg at sealevel and 700mmHg at the top of a mountain. If the density of mercury is  $13,600\text{kg/m}^3$  and average density of air is  $1.30\text{kg/m}^3$ , calculate the height of the mountain.(3 mks)

22. In a vacuum flask, the walls enclosing the vacuum are silvered on the inside. State the reason for this.(1mk)

23. The figure below shows the shapes formed when drops of water and mercury are placed on the surface of a clean glass plate

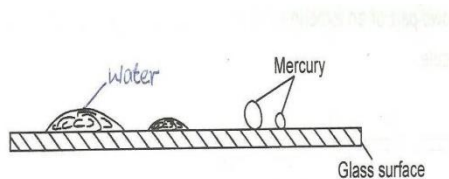

Explain the difference in the shapes.

Explain the difference in the shapes.

(2mks)

24. Explain why air is not used as a brake fluid.

(1mk)

25.  $20\text{cm}^3$  of water is mixed with  $30\text{cm}^3$  of liquid L. Calculate the density of the mixture given that the density of water is  $1000\text{kg/m}^3$  and that of liquid L is  $800\text{kg/m}^3$ . (3 mks)

26. State four uses of the Electroscope (4mks)

27. An object of height 5m is placed 10m away from a pinhole camera. Calculate:

**FOR MARKING SCHEMES CALL/TEXT/WHATSAPP 0705525657**

a) The size of the image if its magnification is 0.01. (2 mrks)

b) The length of the pinhole camera (2 mks)

28. What do you understand by the term temperature (1 mk)



**FOR MARKING SCHEMES CONTACT 0705525657**

**FOR MARKING SCHEMES CALL/TEXT/WHATSAPP 0705525657**